

CHIAVI BUSSOLE ATTREZZI

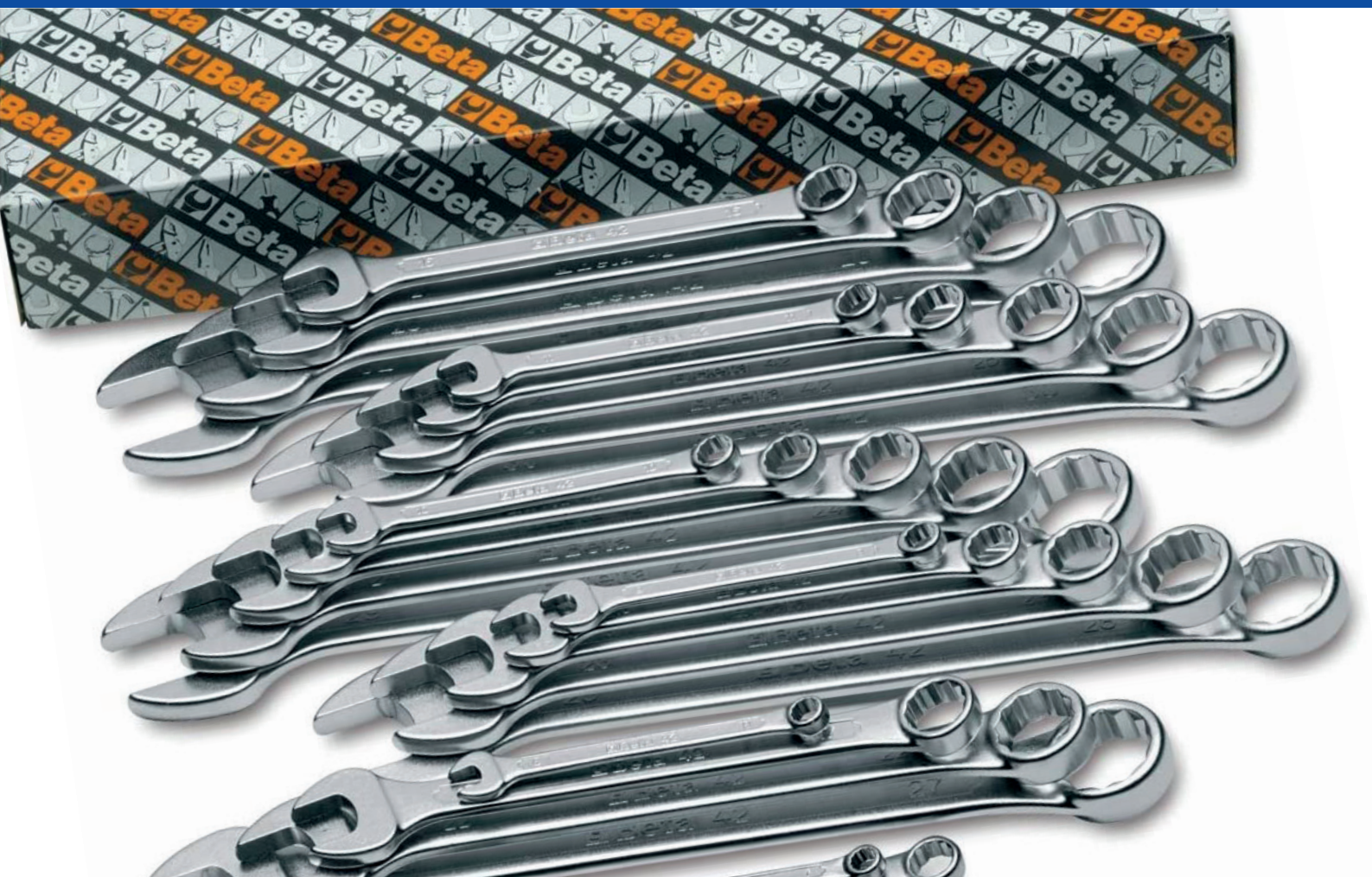

30

punzoni



Ø mm	L mm	
2	125	10 000300020
3	125	10 000300030
4	150	10 000300040
5	150	10 000300050
6	150	10 000300060

31

cacciaspina



Ø mm	L mm	L1 mm	
2	110	22	10 000310002
3	128	35	10 000310003
4	146	45	10 000310004
5	164	55	10 000310005
6	182	65	5 000310006
8	200	80	5 000310008
10	220	95	5 000310010



31/B6



31/SP6

31/B6	2-3-4-5-6-8 mm	1 000310020
42/BV6		1 000420051
31/SP6	2-3-4-5-6-8 mm	1 000310030
31/SPV		1 000310031

31BM

cacciaspina con impugnatura



Ø mm	L mm	L1 mm	
2	168	42	2 000310402
3	180	52	2 000310403
4	191	62	2 000310404
5	200	72	2 000310405
6	221	82	2 000310406
8	235	94	2 000310408



31BM/D6	2-3-4-5-6-8 mm	1 000310420
---------	----------------	-------------

31L

cacciaspina tipo lungo



Ø mm	L mm	L1 mm	
4	175	80	5 000310104
5	175	80	5 000310105
6	175	80	5 000310106

31SE

cacciaspina per spine elastiche



Ø mm	D mm	L mm	L1 mm	
4	2,4	175	80	5 000310204
5	3,0	175	80	5 000310205
6	3,6	175	80	5 000310206



31/B6-LSE	31L: 4-5-6 mm	1 000310320
31SE:	4-5-6 mm	
55/BV6		1 000550151

32

bulini



Ø mm	L mm	L1 mm	
3	100	44	10 000320100
4	125	52	10 000320125
5	150	62	10 000320150

32AU

bulino automatico



Ø mm	L mm	L1 mm	
3	150	23	2 000320160

32AUR

punta di ricambio



Ø mm	L mm	
3		5 000320170

34

scalpelli piatti



L mm	A mm	L1 mm	
125	14,5	45	5 000340001
150	17,0	58	5 000340002
175	21,5	68	5 000340003

35

scalpelli nervati



L mm	A mm	
100	14,5	5 000350001
125	17,0	5 000350002
150	20,5	5 000350003
200	23,0	5 000350004
250	28,5	2 000350005
300	34,0	2 000350006

35PM

scalpelli nervati con paramano



L mm	A mm	
200	23,0	2 000350014
250	28,5	2 000350015
300	34,0	2 000350016

35PMR

ricambi paramano



L mm	
200	1 000350024
250	1 000350025
300	1 000350026

36

ugnetti



L mm	A mm	L1 mm	
125	4	44	5 000360001
150	6	53	5 000360002

37

ugnetti nervati



L mm	A mm	L1 mm	
150	6	45	5 000370001
200	8	55	3 000370002

37PM

ugnetto nervato con paramano



L mm	A mm	
200	8	2 000370012

37PMR

ricambio paramano



L mm	
200	1 000370022



38/B6	
30: 2-3 mm	
32: 4 mm	
34: 125-150 mm	
36: 150 mm	
42/BV6	1 000420051
38/SP6	1 000380009
30: 2-3 mm	
32: 4 mm	
34: 125-150 mm	
36: 150 mm	
38/SPV	1 000380019

42

chiavi combinate



DIN 3113 UNI-ISO 7738

mm	L mm	S1 mm	
5,5x5,5	95	3,4	5 000420005
6x6	95	3,4	5 000420006
7x7	105	3,6	5 000420007
8x8	116	3,9	5 000420008
9x9	127	4,2	5 000420009
10x10	137	4,5	5 000420010
11x11	148	4,8	5 000420011
12x12	158	5,1	5 000420012
13x13	169	5,4	5 000420013
14x14	180	5,7	5 000420014
15x15	190	6,0	5 000420015
16x16	201	6,3	5 000420016
17x17	212	6,7	5 000420017
18x18	222	7,0	5 000420018
19x19	233	7,3	5 000420019
20x20	243	7,6	3 000420020
21x21	254	7,9	3 000420021
22x22	264	8,1	3 000420022
23x23	275	8,3	3 000420023
24x24	285	8,5	3 000420024
25x25	296	8,7	2 000420025
26x26	307	8,9	2 000420026
27x27	317	9,1	2 000420027
28x28	328	9,3	2 000420028
29x29	338	9,5	2 000420029
30x30	349	9,7	2 000420030
32x32	370	10,1	2 000420032
34x34	391	10,5	1 000420034
35x35	412	10,7	1 000420035
36x36	412	10,9	1 000420036
38x38	433	11,3	1 000420038
41x41	465	12,0	1 000420041



42/B9	1 000420064
6-7-8-10-11-13-14-17-19 mm	
42/BV9	1 000420056



42/S14	1 000420067
6-7-8-10-11-12-13-14-15-16-17-19-22-24 mm	
42/S15	1 000420066
6-7-8-10-11-12-13-14-17-19-22-24-27-30-32 mm	
42/S17	1 000420065
6-7-8-9-10-11-12-13-14-15-16-17-18-19-20-21-22 mm	
42/S17X	1 000420068
6-7-8-10-11-12-13-14-15-16-17-19-21-22-24-27-30 mm	
42/S26	1 000420070
6-7-8-9-10-11-12-13-14-15-16-17-18-19-20-21-22-23-24-25-26-27-28-29-30-32 mm	

42/SC9I-E

serie di 9 chiavi combinate con supporto compatto



42/SC9I	1 000420087
8-10-11-12-13-14-15-17-19 mm	
42/SCV9I	1 000420103
42/SC9E	1 000420088
8-10-11-12-13-16-17-18-19 mm	
42/SCV9E	1 000420104



42/SP25	1 000420085
6-7-8-9-10-11-12-13-14-15-16-17-18-19-20-21-22-23-24-25-26-27-28-30-32 mm	
42/SPV2	1 000420090

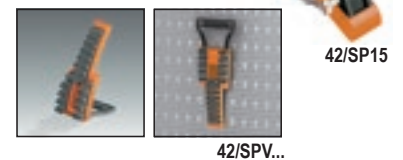

42/SP15	1 000420078
6-7-8-9-10-11-12-13-14-15-16-17-19-22-24 mm	
42/SPV7	1 000420097
42: 8-10-11-13-14-17-19 mm	
55: 6x7-8x9-10x11-12x13-14x15-16x17-18x19 mm	
42/SPV11	1 000420100
42MP: 8-9-10-11-12-13-14-15-16-17-19 mm	
142-142SN: 8-9-10-11-12-13-14-15-16-17-19 mm	
42/SPV15	1 000420102
42: 6-7-8-9-10-11-12-13-14-15-16-17-19-22-24 mm	

42AS

chiavi combinate



mm	L mm		
1/4x1/4	95	2	000420106
9/32x9/32	106	2	000420107
5/16x5/16	116	2	000420108
3/8x3/8	137	2	000420110
7/16x7/16	148	2	000420111
1/2x1/2	169	2	000420113
9/16x9/16	180	2	000420114
19/32x19/32	191	2	000420115
5/8x5/8	201	2	000420116
11/16x11/16	212	2	000420117
3/4x3/4	233	2	000420119
13/16x13/16	254	2	000420121
7/8x7/8	264	2	000420122
15/16x15/16	285	2	000420124
1x1	296	2	000420125
1.1/16x1.1/16	317	2	000420127
1.1/8x1.1/8	338	2	000420129
1.1/4x1.1/4	370	2	000420132
1.5/16x1.5/16	391	1	000420133
1.3/8x1.3/8	412	1	000420135
1.7/16x1.7/16	412	1	000420136
1.1/2x1.1/2	433	1	000420138



42AS/B9	1	000420155
1/4-5/16-3/8-7/16-1/2		
9/16-5/8-11/16-3/4		



42AS/13	1	000420163
1/4-5/16-3/8-7/16-1/2-9/16-5/8		
11/16-3/4-13/16-7/8-15/16-1		
42AS/16	1	000420166
1/4-5/16-3/8-7/16-1/2-9/16-5/8		
11/16-3/4-13/16-7/8-15/16-1-1.1/16-1.1/8-1.1/4		
42AS/17	1	000420168
1/4-9/32-5/16-3/8-7/16-1/2-9/16-19/32-5/8-11/16-3/4-13/16-7/8-15/16-1-1.1/16-1.1/8		

42MP

chiavi combinate lucide



DIN 3113 UNI-ISO 7738

mm	L mm		
6x6	95	5	000420606
7x7	105	5	000420607
8x8	116	5	000420608
9x9	127	5	000420609
10x10	137	5	000420610
11x11	148	5	000420611
12x12	158	5	000420612
13x13	169	5	000420613
14x14	180	5	000420614
15x15	190	5	000420615
16x16	201	5	000420616
17x17	212	5	000420617
18x18	222	5	000420618
19x19	233	5	000420619
20x20	243	3	000420620
21x21	254	3	000420621
22x22	264	3	000420622
24x24	285	3	000420624
27x27	317	3	000420627
30x30	349	3	000420630
32x32	370	3	000420632



42MP/B9	1	000420651
6-7-8-10-11-13-14-17-19 mm		
42/BV9	1	000420056

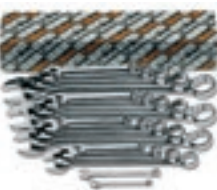

42MP/S17	1	000420652
6-7-8-9-10-11-12-13-14-15-16-17-18-19-20-21-22 mm		
42MP/S21	1	000420653
6-7-8-9-10-11-12-13-14-15-16-17-18-19-20-21-22-24-27-30-32 mm		

42LMP

chiavi combinate lunghe lucide



mm	L mm		
8x8	148	2	000420508
9x9	167	2	000420509
10x10	172	2	000420510
11x11	186	2	000420511
12x12	197	2	000420512
13x13	207	2	000420513
14x14	223	2	000420514
15x15	233	2	000420515

mm	L mm		
16x16	243	2	000420516
17x17	261	2	000420517
18x18	270	2	000420518
19x19	280	2	000420519
21x21	301	2	000420521
22x22	318	2	000420522
24x24	338	2	000420524
27x27	376	2	000420527
30x30	394	2	000420530
32x32	435	2	000420532



42LMP/S14	1	000420551
8-9-10-11-12-13-14-15-16-17-18-19-21-22 mm		
42LMP/S18	1	000420552
8-9-10-11-12-13-14-15-16-17-18-19-21-22-24-27-30-32 mm		

42SLIM

chiavi combinate a testa ribassata



DIN 3113 UNI-ISO 7738

mm	L mm	S1 mm		
8x8	116	3,4	5	000420408
10x10	137	3,8	5	000420410
11x11	148	3,8	5	000420411
12x12	158	4,2	5	000420412
13x13	169	4,4	5	000420413
14x14	180	4,6	5	000420414
15x15	190	4,7	5	000420415
16x16	201	4,7	5	000420416
17x17	212	5,1	5	000420417
18x18	222	5,1	5	000420418
19x19	233	5,6	5	000420419



42SLIM/B8I	1	000420468
10-11-12-13-14-15-17-19 mm		
42SLIM/B8E	1	000420469
10-11-12-13-16-17-18-19 mm		
42SLIM/S11	1	000420471
8-10-11-12-13-14-15-16-17-18-19 mm		

Beta

Beta
INOX
STAINLESS STEEL

258

90

chiavi poligonali doppie curve



DIN 838 ISO 10104

mm	L mm	
6x7	165	5 000900006
8x9	180	5 000900012
8x10	180	5 000900015
10x11	195	5 000900018
10x12	195	5 000900021
11x13	215	5 000900024
12x13	215	5 000900027
12x14	215	5 000900030
14x15	230	5 000900033
14x17	250	5 000900036
16x17	250	5 000900039
17x19	265	5 000900042
18x19	265	5 000900045
19x22	285	3 000900048
20x22	285	3 000900051
21x23	305	2 000900057
22x24	305	2 000900060
24x26	325	2 000900063
24x27	325	2 000900067
25x28	340	2 000900070
27x29	355	2 000900073
27x30	355	2 000900076
27x32	375	2 000900078
30x32	375	2 000900080
32x36	395	1 000900088
34x36	415	1 000900089
35x38	415	1 000900091
36x41	435	1 000900094
41x46	460	1 000900097
46x50	500	1 000900100



90/B8 1 000900154
6x7-8x9-10x11-12x13
14x15-16x17-18x19
20x22 mm

90/BV8 1 000900155



90/S8 1 000900162
6x7-8x9-10x11-12x13
14x15-16x17-18x19
20x22 mm

90/S12 1 000900166
6x7-8x9-10x11-12x13
14x15-16x17-18x19
20x22-21x23-24x26
25x28-30x32 mm

90/S12X 1 000900167
6x7-8x9-10x11-12x13
14x15-16x17-18x19
20x22-21x23-24x27
25x28-30x32 mm

90/S13 1 000900170
6x7-8x9-10x11-12x13
14x15-16x17-18x19
20x22-21x23-24x26
25x28-27x29-30x32 mm



90/SP13 1 000900174
6x7-8x9-10x11-12x13
14x15-16x17-18x19
20x22-21x23-24x26
25x28-27x29-30x32 mm

55/SPV 1 000550190

90AS

chiavi poligonali doppie curve



mm	L mm	
1/4x5/16	165	2 000900203
5/16x11/32	180	2 000900206
5/16x3/8	180	2 000900209
3/8x7/16	195	2 000900212
7/16x1/2	215	2 000900215
1/2x9/16	230	2 000900218
9/16x5/8	230	2 000900221
19/32x11/16	250	2 000900222
5/8x11/16	250	2 000900224
5/8x3/4	265	2 000900227
11/16x3/4	265	1 000900230
11/16x13/16	265	1 000900233
3/4x25/32	265	1 000900235
3/4x7/8	285	1 000900237
13/16x7/8	285	1 000900240
7/8x15/16	305	1 000900243
15/16x1	325	1 000900252
1.1/16x1.1/4	375	1 000900258
1.1/8x1.5/16	375	1 000900261



90AS/8 1 000900298
1/4x5/16-5/16x11/32
3/8x7/16-1/2x9/16
5/8x11/16-11/16x3/4
13/16x7/8-15/16x1

90AS/10 1 000900300
1/4x5/16-5/16x11/32
3/8x7/16-1/2x9/16
5/8x11/16-11/16x3/4
13/16x7/8-15/16x1
1.1/16x1.1/4-1.1/8x1.5/16

Beta

91

chiavi poligonali curve



mm	Ø mm	
24	38	1 000910024
27	41	1 000910027
30	48	1 000910030
32	49	1 000910032
36	54	1 000910036
41	62	1 000910041
46	69	1 000910046
50	76	1 000910050
55	81	1 000910055
60	90	1 000910060
65	98	1 000910065
70	105	1 000910070
75	110	1 000910075
80	125	1 000910080
85	125	1 000910085
90	140	1 000910090
95	140	1 000910095
100	143	1 000910100
105	146	1 000910105

92

leve di manovra per art. 91



	L mm	91 mm	Ø mm	
92/1	460	24÷30	19	1 000920010
92/2	610	32÷41	22	1 000920020
92/3	760	46÷55	25	1 000920030
92/4	860	60÷105	30	1 000920040

93

chiave per ponteggi



mm	L mm	
21x22	310	3 000930021

93C

chiavi a cricchetto per ponteggi



mm	L mm	
17x19	310	1 000930117
19x22	310	1 000930119
19x24	310	1 000930120
21x22	365	1 000930121
36x38	445	1 000930136

chiavi per raccordi tubi



DIN 3118

mm	L mm		
8x10	140	2	000940008
9x11	153	2	000940009
10x11	153	2	000940010
11x13	175	2	000940011
12x14	175	2	000940012
13x15	175	2	000940013
14x15	175	2	000940014
14x17	195	2	000940015
17x19	212	2	000940017
19x22	228	2	000940019
22x24	242	2	000940022
24x27	260	2	000940024
30x32	300	2	000940030
36x41	320	1	000940036



94/S6

8x10-10x11-11x13-12x14
17x19-19x22 mm

1 000940050

94/S10

8x10-9x11-10x11-11x13
12x14-17x19-19x22
22x24-24x27-30x32 mm

1 000940052

95

chiavi poligonali doppie diritte



DIN 837 ISO 10103

mm	L mm		
6x7	120	3	000950161
8x9	135	3	000950162
10x11	150	3	000950163
12x13	165	3	000950164
14x15	185	3	000950165
16x17	210	3	000950166
17x19	225	3	000950167
18x19	225	2	000950168
20x22	240	2	000950169
21x23	255	2	000950170
24x26	270	2	000950171
25x28	285	2	000950172
27x29	315	2	000950173
30x32	335	2	000950174



95/S8

6x7-8x9-10x11-12x13
14x15-16x17-18x19
20x22 mm

1 000950177

95/S13

6x7-8x9-10x11-12x13
14x15-16x17-18x19
20x22-21x23-24x26
25x28-27x29-30x32 mm

1 000950179

95FTX

chiavi doppie diritte per viti
con teste a profilo Torx®

	L mm		
E6xE8	115	2	000950306
E10xE12	143	2	000950310
E14xE18	177	2	000950314
E20xE24	224	2	000950320



95FTX/S4

E6xE8-E10xE12
E14xE18-E20xE24

1 000950325

96

chiavi maschio esagonale piegate
cromate

ISO 2936

mm	L mm	L1 mm		
0,9	35	8	20	000960013
1,3	39	10	20	000960014
1,5	45	15	20	000960015
2	50	17	20	000960020
2,5	57	20	20	000960025
3	64	22	20	000960030
3,5	68	25	20	000960035
4	72	28	20	000960040
4,5	78	30	20	000960045
5	83	32	20	000960050
5,5	88	35	20	000960055
6	94	37	20	000960060
7	99	40	10	000960070
8	105	43	10	000960080
9	111	46	10	000960090
10	119	49	10	000960100
11	126	52	10	000960110
12	134	56	10	000960120
13	142	62	10	000960130
14	151	69	10	000960140
16	165	75	5	000960160
17	174	79	5	000960170
19	196	88	5	000960190
22	216	100	3	000960220
24	242	112	1	000960240
27	271	125	1	000960270
30	309	140	1	000960300
32	341	155	1	000960312
36	385	174	1	000960316



96/ST6

2,5-3-4-5-6-8 mm

3 000960370



96/BGS7

1,5-2-2,5-3-4-5-6 mm

1 000960367



96/BG7

2,5-3-4-5-6-8-10 mm

1 000960368



96/B8

2-2,5-3-4-5-6-8-10 mm

5 000960386

96/B10

1,5-2-2,5-3-4-5-6-8-10-12 mm

5 000960380

96N/BV

1 000960651



96/SC9

1,5-2-2,5-3-4-5-6-8-10 mm

1 000960374

96/SCV

1 000960985



96/SC12

2-2,5-3-3,5-4-4,5-5
6-7-8-9-10 mm

1 000960395

96/SCV12

1 000960975



96N

chiavi maschio esagonale piegate
brunite



ISO 2936

mm	L mm	L1 mm		
0,9	32	10	20	000960409
1,3	44	12	20	000960413
1,5	46	15	20	000960415
2	51	17	20	000960420
2,5	57	20	20	000960425
3	64	22	20	000960430
3,5	68	25	20	000960435
4	72	28	20	000960440
4,5	78	30	20	000960445
5	83	32	20	000960450
6	94	37	20	000960460
7	99	40	10	000960470
8	105	43	10	000960480
9	111	46	10	000960490
10	119	49	10	000960500
11	126	52	10	000960510
12	134	56	10	000960520
13	142	62	10	000960530
14	151	69	10	000960540
16	165	72	5	000960560
17	174	79	5	000960570
19	194	88	5	000960590
22	216	99	1	000960592
24	242	111	1	000960594



96N/ST6 3 000960640
2,5-3-4-5-6-8 mm



96N/G7 3 000960645
2,5-3-4-5-6-8-10 mm
96N/G7A 3 000960643
1,5-2-2,5-3-4-5-6 mm



96N/B10 5 000960650
1,5-2-2,5-3-4-5-6
8-10-12 mm
96N/BV 1 000960651



96N/SC9 1 000960644
1,5-2-2,5-3-4-5-6-8-10 mm
96N/SCV 1 000960986



96N/SC12 1 000960661
2-2,5-3-3,5-4-4,5-5
6-7-8-9-10 mm
96N/SCV12 1 000960976

96C/AS

chiavi maschio esagonale piegate
cromate

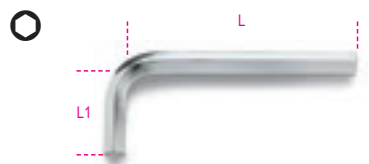

"	L mm	L1 mm			g
1/16	46	16	1,01	20	000961702
3/32	53	19	2,70	20	000961706
1/8	60	22	5,33	20	000961710
5/32	67	25	9,33	20	000961714
3/16	74	28	14,87	20	000961716
7/32	81	32	22,00	20	000961718
1/4	89	35	31,40	20	000961720
5/16	103	40	56,16	10	000961724
3/8	117	45	91,31	10	000961728



96C-AS/SC9 1 000961753
1/16-3/32-1/8-5/32-3/16-
7/32-1/4-5/16-3/8



96AS

chiavi maschio esagonale piegate
brunite



"	L mm	L1 mm		
1/30 (0,035")	44	14	20	000960698
1/20 (0,050")	44	15	20	000960701
1/16	46	16	20	000960702
5/64	50	18	20	000960704
3/32	53	19	20	000960706
7/64	57	21	20	000960708
1/8	60	22	20	000960710
9/64	64	24	20	000960712
5/32	68	25	20	000960714
3/16	75	29	20	000960716
7/32	82	32	20	000960718
1/4	89	35	20	000960720
5/16	103	40	10	000960724
3/8	117	44	10	000960728
7/16	132	49	10	000960730
1/2	149	54	10	000960732
9/16	151	69	2	000960734
5/8	165	72	1	000960736
3/4	194	88	1	000960738



96AS/SC9 1 000960743
1/16-3/32-1/8-5/32-3/16
7/32-1/4-5/16-3/8
96AS/SCV 1 000960744



96AS/T7 3 000960740
3/32-1/8-5/32
3/16-7/32-1/4-5/16



96AS/G7 3 000960745
3/32-1/8-5/32
3/16-1/4-5/16-3/8



96AS/BG7 1 000960747
3/32-1/8-5/32-3/16
1/4-5/16-3/8



96AS/B11
1/20-1/16-5/64-3/32
1/8-5/32-3/16-7/32
1/4-5/16-3/8
96N/BV

1 000960749
1 000960651

96LC

chiavi maschio esagonale piegate
tipo lungo, cromate



ISO 2936

mm	L mm	L1 mm	
2	101	17	20 000960320
2,5	113	20	20 000960321
3	127	22	20 000960322
3,5	138	25	20 000960323
4	142	28	20 000960324
4,5	154	28	20 000960325
5	163	32	20 000960326
6	184	37	20 000960327
7	194	40	10 000960328
8	205	43	10 000960329
9	216	46	10 000960330
10	231	49	10 000960331
12	259	56	10 000960332



96LC/SC8
2-2,5-3-4-5-6-8-10 mm
96LC/SCV

1 000960334
1 000960983



96LC/SC12
2-2,5-3-3,5-4-4,5-5
6-7-8-9-10 mm
96LC/SCV12

1 000960337
1 000960977

96L

chiavi maschio esagonale piegate
tipo lungo, brunite



ISO 2936

mm	L mm	L1 mm	
2	99	15	20 000960820
2,5	110	17	20 000960825
3	124	19	20 000960830
3,5	135	21	20 000960835
4	138	24	20 000960840
4,5	150	25	20 000960845
5	158	27	20 000960850
6	178	31	20 000960860
7	187	33	10 000960870
8	197	35	10 000960880
9	207	37	10 000960890
10	221	39	10 000960900
12	247	44	10 000960920



96L/SC8
2-2,5-3-4-5-6-8-10 mm
96L/SCV

1 000960924
1 000960987



96L/SC12
2-2,5-3-3,5-4-4,5-5
6-7-8-9-10 mm
96L/SCV12

1 000960929
1 000960978

96BPC

chiavi maschio esagonale piegate
con estremità sferica, cromate

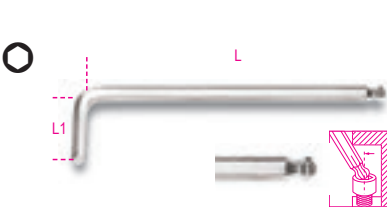

mm	L mm	L1 mm	
1,5	79	13	10 000960340
2	84	15	10 000960341
2,5	89	17	10 000960342
3	99	19	10 000960343
4	108	24	10 000960344
5	126	27	10 000960345
6	148	31	10 000960346
7	157	33	5 000960353
8	168	35	5 000960347
10	187	39	5 000960348
12	220	55	5 000960352



96BPC/SC9
1,5-2-2,5-3-4-5-6-8-10 mm
96BPC/SCV

1 000960354
1 000960984

96BP

chiavi maschio esagonale
piegate con estremità sferica, brunite

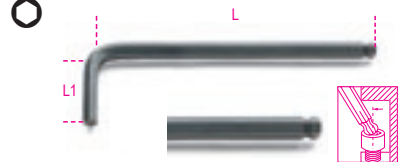

mm	L mm	L1 mm	
1,5	79	13	10 000960960
2	84	15	10 000960961
2,5	89	17	10 000960962
3	99	19	10 000960963
4	108	24	10 000960965
5	126	27	10 000960967
6	148	31	10 000960968
8	168	35	5 000960970
10	187	39	5 000960972
12	220	55	5 000960973



96BP/SC9
1,5-2-2,5-3-4-5-6-8-10 mm
96BP/SCV

1 000960974
1 000960988

96LBP

chiavi maschio esagonale
piegate con estremità sferica,
modello extralungo, cromate

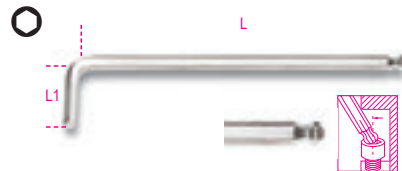

mm	L mm	L1 mm	
1,5	90	15	5 000961340
2	100	17	5 000961341
2,5	112	20	5 000961342
3	127	22	5 000961343
4	144	27	5 000961344
5	163	32	5 000961345
6	184	37	5 000961346
8	204	44	2 000961348
10	230	49	2 000961350



96LBP/SC9 1 000961354
1,5-2-2,5-3-4-5-6-8-10 mm
96LBP/SCV 1 000961984

96BP/AS

chiavi maschio esagonale
piegate con estremità sferica, brunate

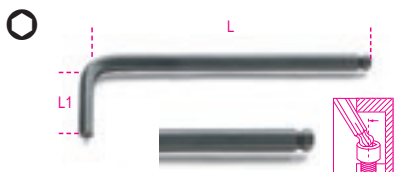

"	L mm	L1 mm		
3/32	89	17	10	000960989
1/8	98	18	10	000960990
5/32	108	24	10	000960991
3/16	126	26	10	000960992
7/32	139	28	10	000960993
1/4	152	31	10	000960994
5/16	168	34	5	000960995
3/8	190	39	5	000960996



96BP-AS/SC9 1 000961000
1/16-3/32-1/8-5/32-3/16
7/32-1/4-5/16-3/8
96BP-AS/SCV 1 000961001



96BP-AS/8 1 000960997
3/32-1/8-5/32-3/16-7/32
1/4-5/16-3/8
96BP-AS/BV 1 000960998

96BPA

chiavi maschio esagonale
piegate a 110° con estremità sferica,
modello lato extra corto, cromate



mm	L mm	L1 mm		
1,5	71	9	5	000961960
2	86	11	5	000961961
2,5	96	13	5	000961962
3	104	15	5	000961963
4	116	17	5	000961964
5	132	19	5	000961965
6	155	21	5	000961966
8	176	24	2	000961968
10	200	27	2	000961970



96BPA/SC9 1 000961974
1,5-2-2,5-3-4-5-6-8-10 mm
96BPA/SCV 1 000961988

96T

chiavi maschio esagonale piegate
con impugnatura di manovra



mm	L mm	L1 mm		
2	139	52	5	000960934
2,5	153	55	5	000960935
3	153	55	5	000960936
3,5	179	70	5	000960937
4	179	70	5	000960938
4,5	200	84	5	000960939
5	200	84	5	000960940
6	221	103	5	000960941
7	236	106	3	000960942
8	255	117	3	000960943
10	285	132	3	000960945



96T/S6 1 000960952
2-2,5-3-4-5-6 mm
96T/S8 1 000960933
2-2,5-3-4-5-6-8-10 mm
96T/S11 1 000960951
2-2,5-3-3,5-4-4,5-5-6-7-8-10 mm



96T/SP11 1 000960957
2-2,5-3-3,5-4-4,5-5
6-7-8-10 mm
96T/SPV 1 000960958
96T/S11
97TTX/S11

96T/AS

chiavi maschio esagonale piegate
con impugnatura di manovra



"	L mm	L1 mm		
3/32	153	55	2	000960669
7/64	153	55	2	000960670
1/8	179	70	2	000960671
9/64	179	70	2	000960672
5/32	200	84	2	000960673
3/16	200	84	2	000960674
7/32	221	103	2	000960675
1/4	236	106	2	000960676
5/16	255	117	2	000960678
3/8	285	132	2	000960680

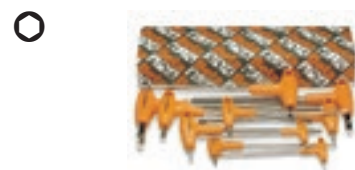

96T/AS8 1 000960682
3/32-7/64-1/8-5/32-3/16-
1/4-5/16-3/8
96T/AS10 1 000960683
3/32-7/64-1/8-9/64-5/32
3/16-7/32-1/4-5/16-3/8

Beta

Beta
INOX
STAINLESS STEEL

96TBP

chiavi maschio esagonale piegate
con estremità sferica ed impugnatura
di manovra



	L	L1		
mm	mm	mm		
2,5	153	55	3	000960685
3	153	55	3	000960686
4	179	70	3	000960687
5	200	84	3	000960688
6	221	103	3	000960689
8	255	117	2	000960690
10	285	132	2	000960692



96TBP/S6
2,5-3-4-5-6-8 mm

97TX

chiavi maschio piegate
per viti con impronta Torx®



	L	L1		
mm	mm	mm		
T6	42	16	5	000970006
T7	48	16	5	000970007
T8	48	16	5	000970008
T9	48	16	5	000970009
T10	51	17	5	000970010
T15	54	18	5	000970015
T20	57	19	5	000970020
T25	60	20	5	000970025
T27	64	21	5	000970027
T30	70	24	5	000970030
T40	76	26	5	000970040
T45	83	29	5	000970045
T50	95	32	5	000970050
T55	108	35	5	000970055
T60	120	38	5	000970060



97TX/ST8
T9-T10-T15-T20-T25
T27-T30-T40



97TX/G8
T9-T10-T15-T20-T25
T27-T30-T40



97TX/BG8
T9-T10-T15-T20-T25-T27-T30-T40



97TX/SC8
T9-T10-T15-T20-T25
T27-T30-T40
97TX/SCV



97TX/B13
T6-T7-T8-T9-T10-T15-T20
T25-T27-T30-T40-T45-T50
96N/BV

97BTX

chiavi maschio piegate
con un'estremità sferica
per viti con impronta Torx®

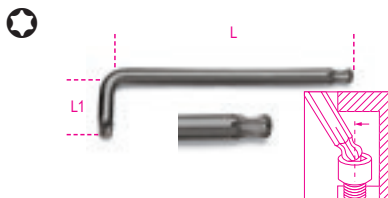

	L	L1		
mm	mm	mm		
T9	80	16	5	000970109
T10	86	17	5	000970110
T15	90	18	5	000970115
T20	95	19	5	000970120
T25	100	20	5	000970125
T27	105	21	5	000970127
T30	114	24	5	000970130
T40	124	26	5	000970140
T45	133	28	5	000970145
T50	152	32	3	000970150
T55	164	35	3	000970155



97BTX/SC8
T9-T10-T15-T20-T25-T27-T30-T40
97BTX/SCV



97BTX/B8
T9-T10-T15-T20-T25
T27-T30-T40
96N/BV

97BTXL

chiavi maschio piegate con un'estremità
sferica, modello lungo,
per viti con impronta Torx®

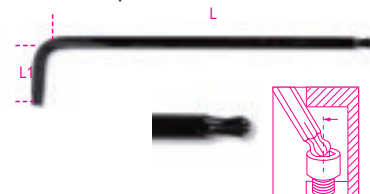

	L	L1		
mm	mm	mm		
T9	80	15	3	000970309
T10	86	17	3	000970310
T15	100	18	3	000970315
T20	110	19	3	000970320
T25	126	20	3	000970325
T27	140	24	3	000970327
T30	160	28	3	000970330
T40	176	32	3	000970340



97BTXL/SC8
T9-T10-T15-T20-
T25-T27-T30-T40
97BTXL/SCV

97RTX

chiavi maschio piegate
per viti con impronta
Tamper Resistant Torx®



	L	L1		
mm	mm	mm		
T9	56	16	5	000970209
T10	62	17	5	000970210
T15	72	17	5	000970215
T20	83	18	5	000970220
T25	90	18	5	000970225
T27	100	20	5	000970227
T30	105	24	5	000970230
T40	112	26	5	000970240



97RTX/SC8 T9-T10-T15-T20-T25 T27-T30-T40	1 000970263
97RTX/SCV	1 000970984



97RTX/B8 T9-T10-T15-T20-T25 T27-T30-T40	1 000970260
96N/BV	1 000960651

97TTX

chiavi maschio piegate
con impugnatura
per viti con impronta Torx®

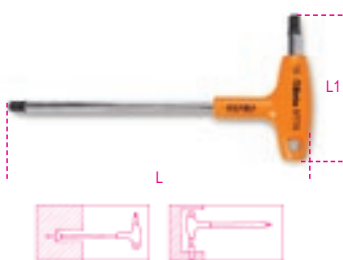

	L mm	L1 mm	
T6	130	52	3 000970706
T7	130	52	3 000970707
T8	139	52	3 000970708
T9	139	52	3 000970709
T10	179	70	3 000970710
T15	179	70	3 000970715
T20	179	70	3 000970720
T25	179	70	3 000970725
T27	200	84	3 000970727
T30	200	84	3 000970730
T40	221	103	3 000970740
T45	236	106	2 000970745
T50	255	117	2 000970750



97TTX/S6 T10-T15-T20-T25-T30-T40	1 000970791
97TTX/S8 T8-T10-T15-T20-T25- T27-T30-T40	1 000970808
97TTX/S11 T8-T9-T10-T15-T20-T25 T27-T30-T40-T45-T50	1 000970800
97TTX/S13 T6-T7-T8-T9-T10-T15-T20-T25 T27-T30-T40-T45-T50	1 000970813



97TTX/SP11 T8-T9-T10-T15-T20-T25 T27-T30-T40-T45-T50	1 000970840
96T/SPV 96T/S11 97TTX/S11	1 000960958

98XZN

chiavi a profilo XZN®



DIN 65253

	L mm	L1 mm	
M5	83	25	5 000980005
M6	89	30	5 000980006
M8	97	32	5 000980008
M10	106	35	5 000980010
M12	116	37	5 000980012
M14	118	45	5 000980014
M16	125	45	5 000980016



98XZN/B5 M5-M6-M8-M10-M12	1 000980650
96N/BV	1 000960651

99

chiavi a settore con nasello quadro
per ghiera



UNI 6752

	A mm	
12-14	1,5	3 000990012
16-18-20	1,8	3 000990016
22-25-28	1,8	3 000990022
30-32	2,1	3 000990030
34-36-38	2,4	3 000990034
40-42	2,4	3 000990040
45-50	2,5	3 000990045
52-55-58	2,5	3 000990052
62-65	3,1	3 000990062
68-70-75	3,1	3 000990068
80-85-90	3,8	2 000990080
92-95	4,3	2 000990092
98-100	4,3	2 000990098
105-110-115	4,4	1 000990105
120-125-130	4,9	1 000990120
135-145	6,0	1 000990135
155-165	6,0	1 000990155

99SQ

chiavi a settore articolate
con nasello quadro



	B mm	
15-35	2,7	2 000990215
35-50	3,5	2 000990235
50-80	4,7	2 000990250
80-120	6,2	2 000990280
120-180	7,8	2 000990290

99ST

chiavi a settore articolate
con nasello tondo



	Ø mm	B mm	
15-35	3,0	2,5	2 000990315
35-50	4,0	4,5	2 000990335
50-80	5,0	5,0	2 000990350
80-120	6,0	7,0	2 000990380
120-180	8,0	9,0	2 000990390

99 VN/...

nasello di ricambio per 99ST

	mm	
99ST VN/15	15-35	1 000990295
99ST VN/35	35-50	1 000990296
99ST VN/50	50-80	1 000990297
99ST VN/80	80-120	1 000990298
99ST VN/120	120-180	1 000990299

100

chiave a compasso con naselli tondi



	L mm	Ø min-max mm	
4,9-5,9	250	18÷100	1 001000001
6,9-7,9			

100/KIT

naselli di ricambio per art. 100



100/KIT	1 001000010
----------------	-------------

111

chiavi regolabili a rullino cromate con scala graduata

- Rotazione destrorsa del rullino
- Scala in millimetri e in pollici



DIN 3117 ISO 6787

L mm	L "	A max mm		
100	4	15	3	001110010
150	6	24	3	001110015
200	8	28	3	001110020
250	10	34	3	001110025
300	12	35	3	001110030
380	15	45	3	001110038
450	18	54	2	001110045
600	24	62	1	001110060

111N

chiavi regolabili a rullino fosfatate con scala graduata

- Rotazione sinistrorsa del rullino
- Con scala in millimetri e in pollici



DIN 3117 ISO 6787

L mm	L "	A max mm		
100	4	15	3	001110210
150	6	24	3	001110215
200	8	28	3	001110220
250	10	34	3	001110225
300	12	35	3	001110230
380	15	45	3	001110238
450	18	54	2	001110245

111G

chiavi regolabili a rullino con scala graduata cromate con impugnatura

- Rotazione destrorsa del rullino
- Scala in millimetri e in pollici
- Impugnatura ergonomica



DIN 3117 ISO 6787

L mm	L "	A max mm		
200	8	28	3	001110620
250	10	34	3	001110625
300	12	35	2	001110630

120

chiavi poligonali aperte a cricchetto



mm	L mm		
10	135	1	001200010
11	135	1	001200011
12	135	1	001200012
13	135	1	001200013
14	135	1	001200014
17	185	1	001200017
19	185	1	001200019
22	230	1	001200022
24	230	1	001200024
27	230	1	001200027
30	320	1	001200030
32	320	1	001200032



120/B6	10-11-13	1	001200050
17-19-22 mm			
120/BV		1	001200051

123E1/4

adattatore portainserti 1/4"
per chiavi a cricchetto 10 mm



mm	L mm		
10	20,6	1	001230010

123Q1/4

adattatore a sgancio rapido 1/4"
per chiavi a cricchetto 10 mm

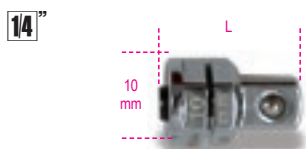

mm	L mm		
10	17,5	1	001230310

123Q3/8

adattatore a sgancio rapido 3/8"
per chiavi a cricchetto 13 mm



mm	L mm		
13	22,5	1	001230313

123Q1/2

adattatore a sgancio rapido 1/2"
per chiavi a cricchetto 19 mm

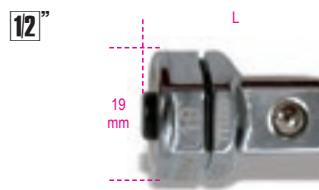

mm	L mm		
19	30,5	1	001230319

123/K4

kit di 4 adattatori per chiavi a cricchetto:
1 adattatore per bits
3 adattatori a sgancio rapido



123/K4		1	001230504
--------	--	---	-----------

141

chiavi combinate dritte
a cricchetto

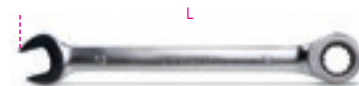

mm	L mm		
8x8	136	3	001410008
9x9	143	3	001410009
10x10	160	3	001410010
11x11	168	3	001410011
12x12	174	3	001410012
13x13	180	3	001410013
14x14	193	2	001410014
15x15	200	2	001410015
16x16	216	2	001410016
17x17	233	2	001410017
18x18	239	2	001410018
19x19	250	2	001410019



141/B6 1 001410066
8-10-13-14-17-19 mm



141/S12 1 001410072
8-9-10-11-12-13-14-15-16-17-18-19 mm

142

chiavi combinate a cricchetto reversibile



mm	L mm		
6x6	136	3	001420006
7x7	136	3	001420007
8x8	136	3	001420008
9x9	143	3	001420009
10x10	159	3	001420010
11x11	168	3	001420011
12x12	174	3	001420012
13x13	180	3	001420013
14x14	190	2	001420014
15x15	200	2	001420015
16x16	216	2	001420016
17x17	233	2	001420017
18x18	239	2	001420018
19x19	248	2	001420019
21x21	285	1	001420021
22x22	285	1	001420022
24x24	325	1	001420024
27x27	355	1	001420027
30x30	420	1	001420030
32x32	420	1	001420032
34x34	482	1	001420034
36x36	482	1	001420036
38x38	482	1	001420038



142/B6 1 001420066
8-10-13-14-17-19 mm
142/BV6 1 001420076
142/B9 1 001420069
8-10-11-12-13-14-15-17-19 mm
142/BV9 1 001420079



142/S15 1 001420074
6-7-8-9-10-11-12-13-14-15-16-17-18-19-22 mm
142/S17 1 001420068
6-7-8-10-11-12-13-14-15-16-17-18-19-21-22-24-27 mm
142/S19 1 001420075
6-7-8-9-10-11-12-13-14-15-16-17-18-19-22-24-27-30-32 mm

142/SC9-E

serie di 9 chiavi combinate a cricchetto reversibile con supporto compatto



142/SC9I 1 001420087
8-10-11-12-13-14-15-17-19 mm
142/SCV9I 1 001420103
142/SC9E 1 001420088
8-10-11-12-13-16-17-18-19 mm
142/SCV9E 1 001420104

142AS

chiavi combinate a cricchetto reversibile



"	L mm		
5/16x5/16	136	2	001420308
3/8x3/8	159	2	001420310
7/16x7/16	168	2	001420311
1/2x1/2	180	2	001420313
9/16x9/16	190	2	001420314
5/8x5/8	216	2	001420316
11/16x11/16	233	2	001420317
3/4x3/4	248	2	001420319



142AS/8 1 001420330
5/16-3/8-7/16-1/2-9/16-5/8-11/16-3/4

142C

chiavi combinate corte diritte a cricchetto



mm	L mm		
8x8	88	2	001420108
9x9	96	2	001420109
10x10	96	2	001420110
11x11	100	2	001420111
12x12	104	2	001420112
13x13	108	2	001420113
14x14	114	2	001420114
15x15	118	2	001420115
16x16	122	2	001420116
17x17	128	2	001420117
18x18	132	2	001420118
19x19	138	2	001420119



142C/A12 1 001420175
8-9-10-11-12-13-14-15-16-17-18-19 mm

142SN

chiavi combinate a cricchetto snodate



mm	L mm		
7x7	136	2	001420207
8x8	136	2	001420208
9x9	143	2	001420209
10x10	160	2	001420210
11x11	168	2	001420211
12x12	174	2	001420212
13x13	180	2	001420213
14x14	193	2	001420214
15x15	200	2	001420215
16x16	216	2	001420216
17x17	233	2	001420217
18x18	239	2	001420218
19x19	250	2	001420219
22x22	285	1	001420222
24x24	325	1	001420224



142SN/S13 1 001420263
7-8-9-10-11-12-13-14-15-16-17-18-19 mm

359CH

adattatore per pilette
con grata a croce per 359



Ø "	L mm		
1 1/2	74	1	003590005

360

giratubi modello stillson



L mm	Ø max "	Ø max mm		
250	1" gas	34	1	003600025
350	1 1/2 gas	49	1	003600035
450	2" gas	60	1	003600045
600	2 1/2 gas	76	1	003600060
900	3 1/2 gas	102	1	003600090

360R/...

kit ricambio per 360
composto da ganascia mobile e ghiera.

360R250	1	003600225
360R350	1	003600235
360R450	1	003600245
360R600	1	003600260
360R900	1	003600290

362

giratubi modello americano



L mm	Ø max "	Ø max mm		
200	1" gas	34	1	003620020
250	1 1/2 gas	49	1	003620025
300	2" gas	60	1	003620030
350	2" gas	60	1	003620035
450	2 1/2 gas	76	1	003620045
600	3" gas	90	1	003620060
900	5" gas	140	1	003620090

362R/...

kit ricambi per 362
composto da: ganascia fissa; ganascia mobile;
ghiera; spina di fissaggio.

362R 200	1	003620220
362R 250	1	003620225
362R 300	1	003620230
362R 350	1	003620235
362R 450	1	003620245
362R 600	1	003620260
362R 900	1	003620290

363

giratubi modello americano
corpo in lega leggera



L mm	Ø max "	Ø max mm		
350	2" gas	60	1	003630035
450	2 1/2 gas	76	1	003630045
600	3" gas	90	1	003630060
900	5" gas	140	1	003630090
1200	6" gas	165	1	003630120

363R/...

kit ricambi per 363
composto da: ganascia fissa; ganascia mobile;
ghiera; spina di fissaggio.

363R 350	1	003630235
363R 450	1	003630245
363R 600	1	003630260
363R 900	1	003630290
363R 1200	1	003630320

365

giratubi modello frontale
corpo in lega leggera

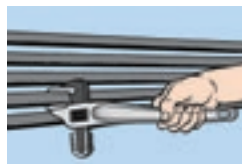

L mm	Ø max "	Ø max mm		
350	2" gas	60	1	003650035
450	2 1/2 gas	76	1	003650045

365R/...

kit ricambi per 365
composto da: ganascia fissa; ganascia mobile;
ghiera; spina di fissaggio.

365R 350	1	003650235
365R 450	1	003650245

366

giratubi tipo leggero



L mm	Ø max "	Ø max mm		
175	1" gas	34	1	003660017
225	1 1/2 gas	49	1	003660022
275	2" gas	60	1	003660027
300	2 1/2 gas	76	1	003660030
350	3" gas	90	1	003660035

374

giratubi modello svedese
ganasce sottili a 45°



DIN 5234

L mm	Ø max "	Ø max mm		
240	1/2" gas	21	1	003740024
320	1" gas	34	1	003740032
410	1 1/2 gas	49	1	003740041
550	2" gas	60	1	003740055
630	3" gas	90	1	003740063

375

giratubi modello svedese
ganasce parallele a 45°



DIN 5234

L mm	Ø max "	Ø max mm		
320	1" gas	34	1	003750032
410	1 1/2 gas	49	1	003750041
550	2" gas	60	1	003750055

376

giratubi modello svedese
ganasce piane a 90°



DIN 5234

L mm	Ø max "	Ø max mm		
320	1" gas	34	1	003760032
410	1 1/2 gas	49	1	003760041
550	2" gas	60	1	003760055
630	3" gas	90	1	003760063

378

giratubi modello svedese
ganasce sottili a 45°



DIN 5234

L mm	Ø max "	Ø max mm		
250	1/2" gas	21	1	003780025
320	1" gas	34	1	003780032
410	1 1/2 gas	49	1	003780041
550	2" gas	60	1	003780055
650	3" gas	90	1	003780065

560/C4+

moltiplicatore di coppia destrorso/sinistrorso e accessori

rapporto 5:1

con piede di reazione



560/18

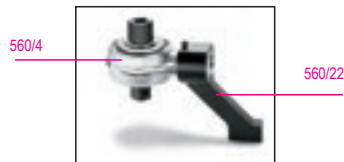

560/4

560/22

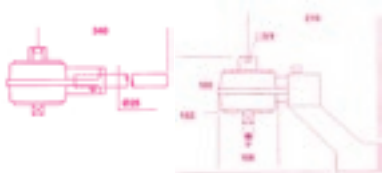

Nm	Kgfm	lbf.ft	□	■	kg
2700	270	2000	3/4	1"	5

560/C4PLUS	1	005600042
560/4	1	005600004
560/18	1	005600018
560/22	1	005600022

400x275x120 mm

560/C6

moltiplicatore di coppia destrorso/sinistrorso in valigetta di materiale plastico

rapporto 6,5:1



Nm	Kgfm	lbf.ft	□	■	kg
1500	150	1106	1/2"	3/4"	6

560/C6	1	005600160
---------------	---	-----------

400x260x110 mm

560/C12

moltiplicatore di coppia destrorso/sinistrorso in valigetta di materiale plastico

rapporto 12:1



Nm	Kgfm	lbf.ft	□	■	kg
2500	250	1844	1/2"	1"	7

560/C12	1	005600210
----------------	---	-----------

400x260x110 mm

561/1

moltiplicatore di coppia destrorso/sinistrorso

rapporto 5:1

con due piedi di reazione

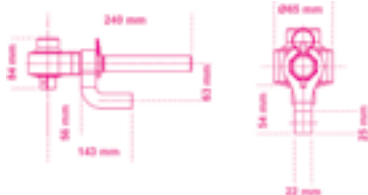

Nm	Kgfm	lbf.ft	□	■	kg
1000	100	740	1/2	3/4	2,7

561/1	1	005610010
--------------	---	-----------

270x210x70 mm

562/1 - 562/2

moltiplicatori di coppia destrorsi/sinistrorsi

rapporto 5:1

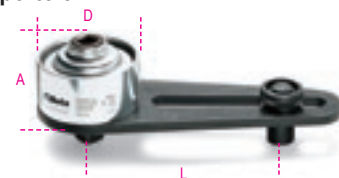

Nm	Kgfm	lbf.ft	□	■	D	A	L min	L max	kg
1700	170	1250	3/4	1"	108	95	85	220	5,3

562/1	1	005620001
--------------	---	-----------

Nm	Kgfm	lbf.ft	□	■	D	A	L min	L max	kg
3400	340	2500	3/4	1"	119	115	85	265	7,0

562/2	1	005620002
--------------	---	-----------

564/3R - 564/4R

moltiplicatori di coppia destrorsi/sinistrorsi

rapporto 25:1

con dispositivo antiritorno



Nm	Kgfm	lbf.ft	□	■	D	A	L	kg
3000	300	2200	1/2	1"	108	188	155	9,2

564/3R	1	005640003
---------------	---	-----------

Nm	Kgfm	lbf.ft	□	■	D	A	L	kg
6000	600	4500	1/2	1"1/2	119	235	200	15,5

564/4R	1	005640004
---------------	---	-----------

565/1R - 565/2R - 565/3R

moltiplicatori di coppia destrorsi/sinistrorsi

rapporto 25:1

con dispositivo antiritorno



Nm	Kgfm	lbf.ft	□	■	D	A	L min	L max	kg
1700	170	1250	1/2	1"	108	125	80	215	7,7

565/1R	1	005650011
---------------	---	-----------

Nm	Kgfm	lbf.ft	□	■	D	A	L min	L max	kg
3400	340	2500	1/2	1"	119	145	85	265	10,1

565/2R	1	005650012
---------------	---	-----------

Nm	Kgfm	lbf.ft	□	■	D	A	L min	L max	kg
3400	340	2500	1/2	1"1/2	119	145	85	265	10,7

565/3R	1	005650013
---------------	---	-----------

Beta

Beta

565/4R

moltiplicatore di coppia destrorso/sinistrorso
rapporto 25:1
con dispositivo antiritorno

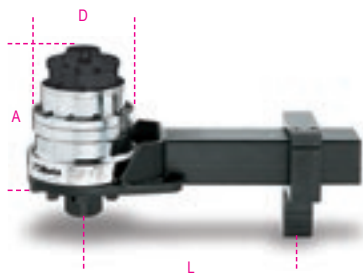

Nm	Kgfm	lbf.ft	□	■	D	A	L min	L max	█
6000	600	4500	1/2	1"1/2	144	180	125	335	17

565/4R 1 005650014

565/5R

moltiplicatore di coppia destrorso/sinistrorso
rapporto 25:1
con dispositivo antiritorno

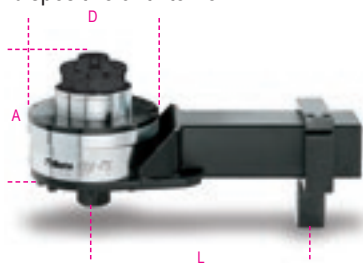

Nm	Kgfm	lbf.ft	□	■	D	A	L min	L max	█
9500	950	7000	3/4	1"1/2	184	180	155	355	25

565/5R 1 005650015

567/4R

moltiplicatore di coppia destrorso/sinistrorso
rapporto 125:1
con dispositivo antiritorno

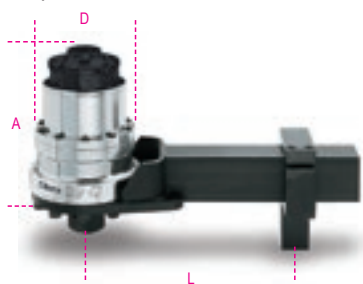

Nm	Kgfm	lbf.ft	□	■	D	A	L min	L max	█
6000	600	4500	1/2	1"1/2	144	210	125	335	19

567/4R 1 005670014

567/5R

moltiplicatore di coppia destrorso/sinistrorso
rapporto 125:1
con dispositivo antiritorno

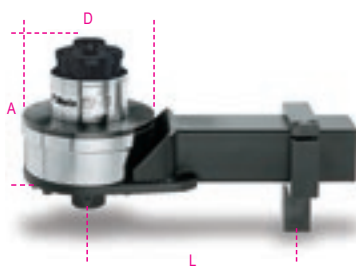

Nm	Kgfm	lbf.ft	□	■	D	A	L min	L max	█
9500	950	7000	1/2	1"1/2	184	210	155	350	27

567/5R 1 005670015

581

giravite dinamometrico a slittamento,
non graduato
adatto a serraggi destrorsi,
precisione di serraggio +/-6%
(per il settaggio della coppia usare
gli artt. 588 - 682)



UNI EN ISO 6789

Nm	gfm	□	█
1,2÷6	120÷600	1/4"	275

581 1 005810001

583

giravite dinamometrico a slittamento
adatto a serraggi destrorsi,
precisione di serraggio +/-6%



UNI EN ISO 6789

Nm	gfm	□	█
0,3÷1,5	30÷150	1/4"	240

583/1,5 1 005830015

Nm	gfm	□	█
0,6÷3	60÷300	1/4"	240

583/3 1 005830030

Nm	gfm	□	█
1,2÷6	120÷600	1/4"	350

583/6 1 005830060

583/C31

1 giravite dinamometrico, 8 chiavi a bussola
esagonali, 20 inserti per avvitatori e 2
accessori



583/C31 1 005830931

Accessorio	Descrizione	Specifica
583/6	1.2 - 6 Nm	
900	4-5-5,5-6-7-8-9-10 mm	
860LP	0,6x4,5 - 1x5,5 - 1,2x6,5 mm	
860PH	PH1 - PH2 (x2) - PH3	
860PE	2-2,5-3-4-5 mm	
860TX	T9-T10-T15-T20-T25-T27-T30-T40	80 mm
882P/80		80 mm
892/0	● 1/4 ■ 1/4	

270x120x45 mm - 1,2 kg

588

misuratore di coppia elettronico digitale

per la verifica e il settaggio dei giravite dinamometrici art.
581-583

Precisione di lettura: ± 1% del valore letto



Nm	lbf.in	□	█
1÷10	10÷90	1/4"	1,8

588 1 005880001

590 - 592

chiavi dinamometriche a lettura diretta
adatte a serraggi destrorsi e sinistrorsi
precisione di serraggio ± 4%



UNI EN ISO 6789

Nm	Kgfm	lbf.in	█	A	L	█
0,3÷4	0,03÷0,4	3÷35	1/4	60	253	0,52

590 1 005900001

Nm	Kgfm	lbf.in	█	A	L	█
0,5÷13,5	0,05÷1,35	4÷120	1/4	60	253	0,52

590/1 1 005900003

Nm	Kgfm	lbf.in	■	A	L	kg
1÷27	0,1÷2,7	10÷240	3/8	70	253	0,52

592/3 1 005920005

Nm	Kgfm	lbf.in	■	A	L	kg
3÷40	0,3÷4	20÷360	3/8	70	253	0,52

592/4 1 005920007

Tabella dei campi di impiego delle chiavi e barre dinamometriche a fine listino

594

chiavi dinamometriche a lettura diretta adatte a serraggi destrorsi e sinistrorsi precisione di serraggio $\pm 4\%$

12"

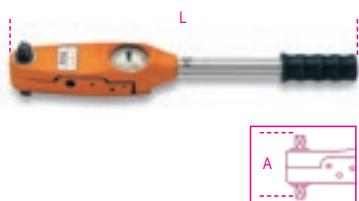

UNI EN ISO 6789

Nm	Kgfm	lbf.ft	■	A	L	kg
6÷80	0,6÷8	5÷60	1/2	85	455	1,35

594/8 1 005940011

Nm	Kgfm	lbf.ft	■	A	L	kg
20÷215	2÷21,5	15÷160	1/2	85	530	1,40

594/21 1 005940015

596 - 598

chiavi dinamometriche a lettura diretta adatte a serraggi destrorsi e sinistrorsi precisione di serraggio $\pm 4\%$

Il raggiungimento della coppia prefissata viene segnalato da una luce e da un suono intermittente



UNI EN ISO 6789

Nm	Kgfm	lbf.ft	■	A	L	kg
80÷400	8÷40	60÷300	3/4	111	710	3,2

596/40SL 1 005960010

Nm	Kgfm	lbf.ft	■	A	L	kg
160÷800	16÷80	120÷600	3/4	115	1025	4,85

596/80SL 1 005960020

Nm	Kgfm	lbf.ft	■	A	L	kg
400÷2000	40÷200	300÷1500	1"	135	1930	16,70

598/200SL 1 005980022

Servizio di taratura dinamometria a fine listino

599DGT

chiave dinamometrica elettronica con cricchetto reversibile, per serraggi destrorsi e sinistrorsi precisione di serraggio $\pm 2\%$ destrorso, $\pm 3\%$ sinistrorso

- Doppia modalità di misura: picco e traccia
- Il raggiungimento della coppia prefissata viene segnalato da avvisori luminosi e da un suono intermittente
- Alimentazione con 2 batterie da 1,5V (incluse)

12"

CE



UNI EN ISO 6789

Nm	Kgfm	lbf.ft	■	D	A	L	kg
12÷60	1,2÷6	8÷44	3/8	30	33	413	0,9

599DGT/6 1 005990003

Nm	Kgfm	lbf.ft	■	D	A	L	kg
20÷100	2÷10	15÷80	1/2	30	37	413	0,9

599DGT/10X 1 005990010

Nm	Kgfm	lbf.ft	■	D	A	L	kg
40÷200	4÷20	30÷150	1/2	40	43	520	2

599DGT/20 1 005990020

Nm	Kgfm	lbf.ft	■	D	A	L	kg
68÷340	6,8÷34	58÷280	1/2	40	43	640	2,35

599DGT/30 1 005990030

599DGT-AN

chiave dinamometrica elettronica a lettura di coppia e angolo con cricchetto reversibile, per serraggi destrorsi (precisione $\pm 2\%$) e sinistrorsi (precisione $\pm 3\%$)

- Tipologie di serraggio: coppia, angolo, coppia + angolo
- Doppia modalità di misura: picco e traccia
- Il raggiungimento della coppia o dell'angolo prefissati vengono segnalati da avvisori luminosi e da un suono intermittente
- Memorizzazione dei dati di serraggio (fino a 1600 valori)
- 9 valori di coppia/angolo preimpostabili
- Blocco di sicurezza dei tasti
- Possibilità di associare la chiave a 16 utilizzatori tramite ID utente
- Tracciabilità dei dati di serraggio. Il software permette di memorizzare data e ora, numero di serie dell'utensile, valore di serraggio impostato, valore raggiunto, e di associarli all'ID utente
- Impugnatura bimatériauale anticivolo
- Inclusi: 2 batterie AA - 1,5V, cavo USB e software

12"

12"

CE



UNI EN 26789
ISO 6789

Nm	Kgfm	lbf.ft	■	D	A	L	kg
20÷100	2÷10	15÷80	1/2	30	33	413	0,9

599DGT-AN/10 1 005990610

Nm	Kgfm	lbf.ft	■	D	A	L	kg
40÷200	4÷20	30÷150	1/2	40	43	520	1,3

599DGT-AN/20 1 005990620

Servizio di taratura dinamometria a fine listino

Beta

600

attrezzi per serraggi angolari

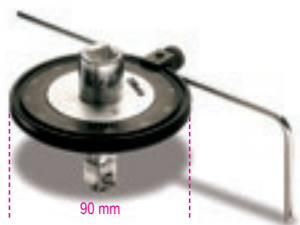

	□	■		
600/1	1/2	1/2	1	006000001
600/2	3/4	3/4	1	006000002

601C

goniometro digitale per serraggi angolari, magnetico il raggiungimento dell'angolo prefissato viene segnalato da avvisatori luminosi e da un suono intermittente

CE



601C			1	006010100

85x80x87 mm - 70 g

601CA

goniometro digitale per serraggi coppia ed angolo il raggiungimento della coppia o dell'angolo prefissati viene segnalato da avvisatori luminosi e da un suono intermittente

12"

CE



	□	■	Nm	
601CA	1/2"	1/2"	10÷200	1 006010120

120x90x120 mm - 240 g

603

chiavi dinamometriche a slittamento per serraggi destrorsi precisione di serraggio ± 6%

14"



UNI EN ISO 6789

Nm	Kgfm	lbf.in	■	A mm	L mm	g
1÷5	0,1÷0,5	10÷45	1/4	35	195	235

603/5	1	006030005
-------	---	-----------

Nm	Kgfm	lbf.in	■	A mm	L mm	g
2÷10	0,2÷1,0	18÷90	1/4	35	195	235

603/10	1	006030010
--------	---	-----------

604B

barre dinamometriche a disinnesto per serraggi destrorsi e sinistrorsi precisione di serraggio ± 6%



UNI EN ISO 6789

Nm	kgfm	lbf.in	Ø mm	L mm	g
1÷5	0,1÷0,5	10÷45	8	220	290

604B/5	1	006040015
--------	---	-----------

Nm	Kgfm	lbf.in	Ø mm	L mm	g
2÷10	0,2÷1,0	18÷90	8	220	300

604B/10	1	006040020
---------	---	-----------

605E

chiavi dinamometriche a scatto con cricchetto reversibile per serraggi destrorsi e sinistrorsi precisione di serraggio ± 6%

14"



UNI EN ISO 6789

Nm	Kgfm	lbf.in	■	A mm	L mm	g
1÷5	0,1÷0,5	10÷45	1/4	20	190	180

605E/5	1	006050105
--------	---	-----------

Nm	Kgfm	lbf.in	■	A mm	L mm	g
2÷10	0,2÷1,0	18÷90	1/4	20	190	180

605E/10	1	006050110
---------	---	-----------

611

cricchetti reversibili per barre dinamometriche 604B/5 e 604B/10



■	L mm		
1/4	42,5	1	006110001

Servizio di taratura
dinamometria
a fine listino

612 ÷ 614

cricchetti reversibili per barre dinamometriche



Gli articoli 612 e 612X non devono essere utilizzati con coppie di serraggio superiori a 100 Nm

	■	L mm	LA mm		
612	3/8	66	32	2	006120000
612X	1/2	66	32	2	006120010
614	1/2	71	32	2	006140000
614X	3/4	71	32	2	006140004

614/50

cricchetto semplice per barre dinamometriche



	■	L mm	LA mm		
614/50	1/2	71	32	2	006140002

Meccanismi rotanti
di ricambio dei cricchetti,
vedi tabella dopo l'art. 929/C8

Beta

615

cricchetti reversibili
per barre dinamometriche
con attacco rettangolare



mm	mm	L mm	LA mm		
9x12	3/8	53	28,8	1	006150010
9x12	1/2	53	28,8	1	006150020
14x18	1/2	70	39,8	1	006150120

616 - 617 - 619

quadri maschi
per barre dinamometriche



mm	mm	L mm	LA mm		
616	1/4	61	32	1	006160000
617	3/8	61	32	1	006170000
619	1/2	63	32	1	006190000

621

accessori portainseri
per barre dinamometriche
con attacco rettangolare,
con magnete



mm	mm	L mm	LA mm		
P 1/4	9x12	1/4	40	28,8	1 006210000
* P 5/16	14x18	5/16	61	32,5	1 006210110

*Attenzione! Ricalcolare il valore di coppia da impostare
come indicato nella tabella in fondo al listino

641

chiavi a forchetta
per barre dinamometriche 604B/5 e 604B/10



mm	L mm		
4	37	1	006410003
5	37	1	006410004
5,5	37	1	006410005
6	37	1	006410006
7	37	1	006410007
8	42	1	006410008
9	42	1	006410009
10	42	1	006410010

Beta

642

chiavi a forchetta
per barre dinamometriche

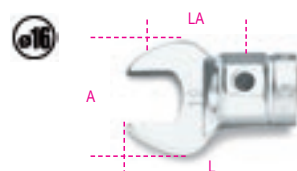

mm	L mm	LA mm	A mm		
8	54	32	22	1	006420008
10	57	32	26	1	006420010
12	58	32	30	1	006420012
13	58	32	30	1	006420013
14	59	32	32	1	006420014
15	59	32	35	1	006420015
16	59	32	38	1	006420016
17	60	32	39	1	006420017
18	61	32	42	1	006420018
19	61	32	43	1	006420019
20	61	32	50	1	006420020
21	62	32	53	1	006420021
22	62	32	53	1	006420022
23	65	32	53	1	006420023
24	63	32	53	1	006420024
26	64	32	59	1	006420026
27	65	32	59	1	006420027
28	66	32	64	1	006420028
30	66	32	66	1	006420030
32	67	32	66	1	006420032
* 36	76	42	80	1	006420036
* 40	77	52	95	1	006420040
* 41	78	52	95	1	006420041
* 46	90	52	95	1	006420046

*Attenzione! Ricalcolare il valore di coppia da impostare
come indicato nella tabella in fondo al listino

643

chiavi a forchetta
per barre dinamometriche
con attacco rettangolare

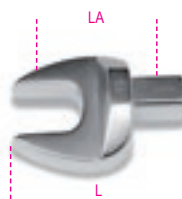

mm	mm	L mm	LA mm		
8	9x12	37	28,8	1	006430008
10	9x12	39	28,8	1	006430010
12	9x12	39	28,8	1	006430012
13	9x12	39	28,8	1	006430013
14	9x12	43	28,8	1	006430014
15	9x12	43	28,8	1	006430015
16	9x12	43	28,8	1	006430016
17	9x12	43	28,8	1	006430017
* 18	9x12	47	36,3	1	006430018
* 19	9x12	51	36,3	1	006430019
* 22	9x12	52	36,3	1	006430022

*Attenzione! Ricalcolare il valore di coppia da impostare
come indicato nella tabella in fondo al listino

mm	mm	L mm	LA mm		
13	14x18	60	39,8	1	006430113
14	14x18	58	39,8	1	006430114
15	14x18	60	39,8	1	006430115
16	14x18	60	39,8	1	006430116
17	14x18	60	39,8	1	006430117
18	14x18	61	39,8	1	006430118
19	14x18	61	39,8	1	006430119
21	14x18	61	39,8	1	006430121
22	14x18	62	39,8	1	006430122
24	14x18	64	39,8	1	006430124
* 27	14x18	68	44,8	1	006430127
* 30	14x18	77	49,8	1	006430130
* 32	14x18	77	49,8	1	006430132
* 34	14x18	80	54,8	1	006430134
* 36	14x18	83	54,8	1	006430136
* 41	14x18	91	64,8	1	006430141

*Attenzione! Ricalcolare il valore di coppia da impostare
come indicato nella tabella in fondo al listino

652

chiavi poligonali
per barre dinamometriche



mm	L mm	LA mm		
8	58	32	1	006520008
10	58	32	1	006520010
12	58	32	1	006520012
13	58	32	1	006520013
14	58	32	1	006520014
15	62	32	1	006520015
16	63	32	1	006520016
17	64	32	1	006520017
18	65	32	1	006520018
19	65	32	1	006520019
21	67	32	1	006520021
22	68	32	1	006520022
24	69	32	1	006520024
26	71	32	1	006520026
27	71	32	1	006520027
30	73	32	1	006520030
32	74	32	1	006520032

*Attenzione! Ricalcolare il valore di coppia da impostare
come indicato nella tabella in fondo al listino

653

chiavi poligonali
per barre dinamometriche
con attacco rettangolare

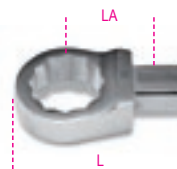

mm	mm	L mm	LA mm		
8	9x12	40	28,8	1	006530008
10	9x12	43	28,8	1	006530010
12	9x12	44	28,8	1	006530012
13	9x12	44	28,8	1	006530013
14	9x12	45	28,8	1	006530014
15	9x12	46	28,8	1	006530015
16	9x12	47	28,8	1	006530016
17	9x12	47	28,8	1	006530017
18	9x12	48	28,8	1	006530018
19	9x12	49	28,8	1	006530019
22	9x12	51	28,8	1	006530022

*Attenzione! Ricalcolare il valore di coppia da impostare
come indicato nella tabella in fondo al listino

mm	mm	L mm	LA mm		
13	14x18	61	39,8	1	006530113
14	14x18	61	39,8	1	006530114
15	14x18	62	39,8	1	006530115
16	14x18	63	39,8	1	006530116
17	14x18	64	39,8	1	006530117
18	14x18	64	39,8	1	006530118
19	14x18	66	39,8	1	006530119
21	14x18	66	39,8	1	006530121
22	14x18	67	39,8	1	006530122
24	14x18	69	39,8	1	006530124
* 27	14x18	76	44,8	1	006530127
* 30	14x18	77	44,8	1	006530130
* 32	14x18	79	44,8	1	006530132
* 34	14x18	80	44,8	1	006530134
* 36	14x18	80	44,8	1	006530136
* 41	14x18	90	49,8	1	006530141

*Attenzione! Ricalcolare il valore di coppia da impostare come indicato nella tabella in fondo al listino

659/15

raccordo con attacco rettangolare femmina 14x18 mm e maschio 9x12 mm



L mm	mm	mm		
* 56	14x18	9x12	1	006590815

*Attenzione! Ricalcolare il valore di coppia da impostare come indicato nella tabella in fondo al listino

659/16

raccordo con attacco rettangolare femmina 9x12 mm e maschio 14x18 mm



L mm	mm	mm		
* 52	9x12	14x18	1	006590816

*Attenzione! Ricalcolare il valore di coppia da impostare come indicato nella tabella in fondo al listino

665

chiave dinamometrica meccanica a lettura digitale con cricchetto reversibile, per serraggi destrorsi, precisione di serraggio $\pm 3\%$

- Impostazione e lettura semplice della coppia tramite valore visualizzato sul display
- Il display rimane acceso con valore di coppia impostato
- Lettura della coppia con cifra decimale
- Spegnimento automatico dopo 10 sec. con impostazione della coppia inferiore alla soglia minima
- Alimentazione con 1 batteria da 3 V (inclusa)



UNI EN ISO 6789

Nm	mm	D mm	A mm	L mm	g
10÷60	3/8	30	33	335	655

665/6 1 006650006

Nm	mm	D mm	A mm	L mm	g
20÷100	3/8	30	33	375	725

665/10 1 006650010

Nm	mm	D mm	A mm	L mm	g
20÷100	1/2	30	37	375	725

665/10X 1 006650011

Nm	mm	D mm	A mm	L mm	g
40÷200	1/2	40	43	470	995

665/20 1 006650020

Nm	mm	D mm	A mm	L mm	g
60÷330	1/2	40	43	590	1260

665/30 1 006650030

665LB

chiave dinamometrica meccanica a lettura digitale con cricchetto reversibile, per serraggi destrorsi, precisione di serraggio $\pm 3\%$

- Unità di misura: lbf.ft
- Impostazione e lettura semplice della coppia tramite valore visualizzato sul display
- Il display rimane acceso con valore di coppia impostato
- Lettura della coppia con cifra decimale
- Spegnimento automatico dopo 10 sec. con impostazione della coppia inferiore alla soglia minima
- Alimentazione con 1 batteria da 3 V (inclusa)



UNI EN ISO 6789

lbf.ft	mm	D mm	A mm	L mm	g
7÷45	3/8	30	33	335	655

665LB/6 1 006650106

lbf.ft	mm	D mm	A mm	L mm	g
15÷75	3/8	30	33	375	725

665LB/10 1 006650110

lbf.ft	mm	D mm	A mm	L mm	g
15÷75	1/2	30	37	375	725

665LB/10X 1 006650111

lbf.ft	mm	D mm	A mm	L mm	g
30÷150	1/2	40	43	470	995

665LB/20 1 006650120

lbf.ft	mm	D mm	A mm	L mm	g
45÷240	1/2	40	43	590	1260

665LB/30 1 006650130

665SW

dispositivo di calibrazione

- Il dispositivo permette la calibrazione delle chiavi serie 665 con l'ausilio dei misuratori di coppia Beta 680 e 682, senza la necessità di smontare la chiave.
- La calibrazione avviene su più punti per compensare il comportamento non lineare della molla.
- Dotato di presa Micro USB per consentire futuri aggiornamenti firmware.



665SW 1 006650100

666N

chiavi dinamometriche a scatto con cricchetto reversibile per serraggi destrorsi precisione di serraggio $\pm 3\%$



UNI EN ISO 6789

Nm	Kgfm	lbf.ft	mm	D mm	A mm	L mm	g
5÷25	0,5÷2,5	4÷18	1/4	25	29	220	300

666N/2 1 006660002

Nm	Kgfm	lbf.ft	mm	D mm	A mm	L mm	g
5÷25	0,5÷2,5	4÷18	3/8	25	29	220	300

666N/2X 1 006660003

Nm	Kgfm	lbf.ft	mm	D mm	A mm	L mm	g
10÷50	1÷5	7÷37	3/8	30	33	325	660

666N/5 1 006660005

Nm	Kgfm	lbf.ft	mm	D mm	A mm	L mm	g
20÷100	2÷10	15÷75	3/8	30	33	367	730

666N/10 1 006660010

Nm	Kgfm	lbf.ft	mm	D mm	A mm	L mm	g
20÷100	2÷10	15÷75	1/2	30	37	367	800

666N/10X 1 006660011

Nm	Kgfm	lbf.ft	mm	D mm	A mm	L mm	g
40÷200	4÷20	30÷150	1/2	40	43	465	1010

666N/20 1 006660020

Nm	Kgfm	lbf.ft	mm	D mm	A mm	L mm	g
60÷300	6÷30	50÷220	1/2	40	43	581	1380

666N/30 1 006660030

666N LBF.IN

chiavi dinamometriche a scatto con cricchetto reversibile per serraggi destrorsi precisione di serraggio $\pm 3\%$
• Scala in libbre-forza per pollice



UNI EN ISO 6789

lbf.in	mm	D mm	A mm	L mm	g
90÷440	3/8	30	33	325	660

666N-LBF.IN/5 1 006660055

lbf.in	mm	D mm	A mm	L mm	g
200÷800	3/8	30	33	367	730

666N-LBF.IN/10 1 006660070

lbf.in	mm	D mm	A mm	L mm	g
200÷800	1/2	30	37	367	800

666N-LBF.IN/10X 1 006660071

lbf.in	mm	D mm	A mm	L mm	g
400÷1800	1/2	40	43	465	1010

666N-LBF.IN/20 1 006660072

lbf.in	mm	D mm	A mm	L mm	g
500÷3000	1/2	40	43	581	1380

666N-LBF.IN/30 1 006660073

667N

chiavi dinamometriche a scatto con cricchetto semplice per serraggi destrorsi e sinistrorsi precisione di serraggio $\pm 3\%$



UNI EN ISO 6789

Nm	Kgfm	lbf.ft	mm	D mm	A mm	L mm	g
40÷200	4÷20	30÷150	1/2	40	43	465	1010

667N/20 1 006670020

Nm	Kgfm	lbf.ft	mm	D mm	A mm	L mm	g
60÷300	6÷30	50÷220	1/2	40	43	581	1380

667N/30 1 006670030

Nm	Kgfm	lbf.ft	mm	D mm	A mm	L mm	g
80÷400	8÷40	60÷295	3/4	50	50	687	2090

667N/40 1 006670040

Meccanismi rotanti di ricambio dei cricchetti, vedi tabella dopo l'art. 929/C8

668N

barre dinamometriche a scatto per serraggi destrorsi e sinistrorsi precisione di serraggio $\pm 3\%$



UNI EN ISO 6789

Nm	Kgfm	lbf.ft	mm	Ø mm	L mm	LB mm	LS mm	g
5÷25	0,5÷2,5	4÷18	16	220	148	32	300	

668N/2 1 006680002

Nm	Kgfm	lbf.ft	mm	Ø mm	L mm	LB mm	LS mm	g
10÷50	1÷5	7÷37	16	332	229	32	590	

668N/5 1 006680005

Nm	Kgfm	lbf.ft	mm	Ø mm	L mm	LB mm	LS mm	g
20÷100	2÷10	15÷75	16	362	269	32	670	

668N/10 1 006680010

Nm	Kgfm	lbf.ft	mm	Ø mm	L mm	LB mm	LS mm	g
40÷200	4÷20	30÷150	16	445	352,6	32	795	

668N/20 1 006680020

Nm	Kgfm	lbf.ft	mm	Ø mm	L mm	LB mm	LS mm	g
60÷300	6÷30	50÷220	16	569	475,9	32	1230	

668N/30 1 006680030

668RG

barra dinamometrica a scatto, non graduata adatta a serraggi destrorsi e sinistrorsi precisione di serraggio $\pm 4\%$ (per il settaggio della coppia usare gli art. 680/40 - 682)



UNI EN ISO 6789

Nm	Kgfm	lbf.ft	mm	Ø mm	L mm	g
8÷60	0,8÷6	6÷44	16	288	550	

668RG/6 1 006680206

Nm	Kgfm	lbf.ft	mm	Ø mm	L mm	g
20÷100	2÷10	15÷80	16	315	600	

668RG/10 1 006680210

Nm	Kgfm	lbf.ft	mm	Ø mm	L mm	g
40÷200	4÷20	30÷150	16	405	780	

668RG/20 1 006680220

Nm	Kgfm	lbf.ft	mm	Ø mm	L mm	g
60÷300	6÷30	50÷220	16	645	1130	

668RG/30 1 006680230

669N

barre dinamometriche a scatto, attacco rettangolare per serraggi destrorsi e sinistrorsi precisione di serraggio $\pm 3\%$



UNI EN ISO 6789

Nm	Kgfm	lbf.ft	mm	mm	L mm	LB mm	LS mm	g
5÷25	0,5÷2,5	4÷18	9x12	215	140	28,8	300	

669N/2 1 006690202

Nm	Kgfm	lbf.ft	mm	mm	L mm	LB mm	LS mm	g
10÷50	1÷5	7÷37	9x12	322	226,8	28,8	590	

669N/5 1 006690205

Nm	Kgfm	lbf.ft	mm	mm	L mm	LB mm	LS mm	g
20÷100	2÷10	15÷75	9x12	362	266,8	28,8	670	

669N/10 1 006690210

Nm	Kgfm	lbf.ft	mm	mm	L mm	LB mm	LS mm	g
40÷200	4÷20	30÷150	9x12	445	345,6	28,8	795	

669N/20 1 006690220

Nm	Kgfm	lbf.ft	mm	mm	L mm	LB mm	LS mm	g
40÷200	4÷20	30÷150	14x18	445	351	39,8	795	

669N/20X 1 006690221

Nm	Kgfm	lbf.ft	mm	mm	L mm	LB mm	LS mm	g
60÷300	6÷30	50÷220	14x18	569	468,5	39,8	1230	

669N/30 1 006690230

Nm	Kgfm	lbf.ft	mm	mm	L mm	LB mm	LS mm	g
80÷400	8÷40	60÷295	14x18	588	563	39,8	2100	

669N/40 1 006690240

671B/C5

barra dinamometrica 604B/5 e accessori



671B/C5 1 006710001

604B/5	1+5 Nm
611	1/4
641	5-6-7-8 mm
900	4-5-5,5-6-7-8-9-10 mm

270x120x45 mm - 1,3 kg

671B/C10

barra dinamometrica 604B/10 e accessori



671B/C10 1 006710002

604B/10	2+10 Nm
611	1/4
641	6-7-8-10 mm
900	4-5-5,5-6-7-8-9-10 mm

270x120x45 mm - 1,4 kg

671N/C10

barra dinamometrica 668N/10 e accessori



671N/C10 1 006710110

668N/10	100 Nm
612	3/8
617	3/8
642	10-13-14-17-19 mm
652	10-13-14-17-19 mm
910A	3/8 8-10-11-13-14-17-19 mm
910/21	125 mm
910/22	250 mm

400x180x45 mm - 4,3 kg

671N/C20

barra dinamometrica 668N/20 e accessori



671N/C20 1 006710120

668N/20	200 Nm
614	1/2
619	1/2
642	10-13-14-17-19 mm
652	10-13-14-17-19 mm
920A	1/2 10-11-13-14-17-19-22 mm
920/20	75 mm
920/21	125 mm
920/22	255 mm

510x180x45 mm - 5,5 kg

671N/C30

barra dinamometrica 668N/30 e accessori



671N/C30 1 006710130

668N/30	300 Nm
614	1/2
619	1/2
642	13-14-17-19 mm
652	13-14-17-19 mm
920A	1/2 13-14-17-19-22-24-27 mm
920/20	75 mm
920/21	125 mm
920/22	255 mm

620x180x45 mm - 5,8 kg

677

chiavi dinamometriche a disinnesto con cricchetto semplice per serraggi destrorsi e sinistrorsi precisione di serraggio $\pm 4\%$



UNI EN ISO 6789

Nm	Kgfm	lbf.ft	D mm	A mm	L mm	kg
100÷500	10÷50	70÷350	70	55	915	5,2

677/50 1 006770050

Nm	Kgfm	lbf.ft	D mm	A mm	L mm	kg
150÷700	15÷70	100÷500	70	55	1140	6,2

677/70 1 006770070

Nm	Kgfm	lbf.ft	D mm	A mm	L mm	kg
300÷1000	30÷100	200÷750	70	55	1470	7,5

677/100 1 006770100

677/C

chiavi dinamometriche a disinnesto con cricchetto semplice per serraggi destrorsi e sinistrorsi precisione di serraggio $\pm 4\%$ in cassetta



UNI EN ISO 6789

Nm	Kgfm	lbf.ft	D mm	A mm	L mm	kg
100÷500	10÷50	70÷350	70	55	915	5,2

677/C50 1 006770606

Nm	Kgfm	lbf.ft	D mm	A mm	L mm	kg
150÷700	15÷70	100÷500	70	55	1140	6,2

677/C70 1 006770611

Nm	Kgfm	lbf.ft	D mm	A mm	L mm	kg
300÷1000	30÷100	200÷750	70	55	1470	7,5

677/C100 1 006770615

Nm	Kgfm	lbf.ft	D mm	A mm	L mm	kg
700÷1500	70÷150	500÷1000	70	70	1475	10,4

677/C150 1 006770620

677/CP200

chiavi dinamometriche a disinnesto con cricchetto semplice per serraggi destrorsi e sinistrorsi precisione di serraggio $\pm 4\%$ in cassetta



UNI EN ISO 6789

Nm	kgfm	lbf.in	D mm	A mm	L mm	kg
900÷2000	90÷200	600÷1500	70	63	1920	13

677/CP200 1 006770720

678/C

chiavi dinamometriche a scatto con cricchetto semplice per serraggi destrorsi e sinistrorsi precisione di serraggio $\pm 4\%$ in cassetta

• Modelli 678/C100 e 678/C150 forniti di prolunga.



UNI EN ISO 6789

678/C100
678/C150

Nm	Kgfm	lbf.ft	D mm	A mm	L mm	kg
130÷650	13÷65	100÷480	63	55	885	3,9

678/C65 1 006780607

Nm	Kgfm	lbf.ft	D mm	A mm	L mm	kg
300÷1000	30÷100	220÷750	75	60	1250	6,0

678/C100 1 006780611

Nm	Kgfm	lbf.ft	D mm	A mm	L mm	kg
500÷1500	50÷150	370÷1100	75	60	1570	8,5

678/C150 1 006780615

677/CV - 678/CV

cassette vuote per chiavi dinamometriche 677 e 678



677/CV1 1 006770450

677/C50-677/C70 1 006780500

678/CV2 1 006780415

678/C100 1 006780415

677/C100-677/C150-678/C150

680

misuratore di coppia elettronico digitale Dynatester 680 per verifica tarature funzionamento destrorso e sinistrorso

• Precisione di lettura: $\pm 1\%$ del valore letto
• 3 unità di misura: Nm - lbf.ft. - lbf.in

CE



	Nm	kg	
680/2,5	1÷25	2,6	1 006800002
680/40	15÷400	4,0	1 006800040
680/100	100÷1000	4,8	1 006800100

682

misuratore di coppia elettronico digitale con trasduttori porziometrici Dynatester 682 funzionamento destrorso e sinistrorso

Alta precisione di lettura
Fornito di uscita seriale RS 232



CARATTERISTICHE TECNICHE:

Precisione di lettura: $\pm 1\%$ del valore letto
Unità di misura selezionabili
Nm-dNm-cNm-Lbf.ft-Lbf.in-Ozf.in-Kgf.m-Kgf.cm-gf.cm
Alimentazione: 90 a 264V AC a 50/60 Hz
Dimensioni: 235x185x185 mm
Verifica di tolleranza secondo norma ISO6789
Indicazione dell'intervallo di accettabilità specifico per ogni chiave dinamometrica testata
Display: Menu selezionabile in 11 lingue
Documentazione allegata
Certificato di calibrazione con rintracciabilità UKAS

	Nm	kg	
682/60	1,2÷60	5,9	1 006820006
682/400	8÷400	6,1	1 006820040
682/1500	30÷1500	6,4	1 006820150

710

chiavi a bussola Macchina serie normale



UNI/ISO 2725 DIN 3129

mm	Ø mm	L mm	Ø1 mm	
7	12,5	28	19	3 007100007
8	13,8	28	19	3 007100008
9	15,0	28	19	3 007100009
10	16,3	28	19	3 007100010
11	17,5	30	19	3 007100011
12	19,0	30	19	3 007100012
13	20,0	30	22	3 007100013
14	21,3	30	22	3 007100014
16	23,8	30	22	3 007100016
17	25,0	30	22	3 007100017
18	26,3	30	22	3 007100018
19	27,5	30	22	3 007100019
21	30,0	32	22	3 007100021
22	32,0	32	22	3 007100022

710/16

raccordo Macchina con attacco quadro femmina 3/8" e maschio 1/2"

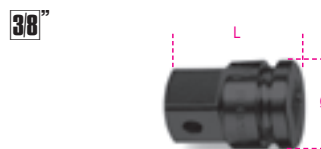

L mm	Ø mm		
32	22	3/8	1/2

710/20

prolunga Macchina con attacchi quadri maschio e femmina 3/8"



L mm	Ø mm		
75	22		

710/21

prolunga Macchina con attacchi quadri maschio e femmina 3/8"



L mm	Ø mm		
125	22		

710/25

snodo Macchina con attacchi quadri maschio e femmina 3/8"

3/8"



L mm
Ø mm
58 24

2 007100830

710/C10

10 chiavi a bussola Macchina

3/8"



710/C10
7-8-10-11-12-13
14-17-19-22 mm

1 007100910

130x55x40 mm - 800 g

710/OR... - 710/SP...

anelli e spine per bussole e accessori Macchina

3/8"

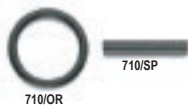

	710 Ø mm	710/16 L mm	
710/OR1	7-12		10 007100921
710/OR2	13-22	32	10 007100922
710/SP1	7-12		10 007100911
710/SP2	13-22	32	10 007100912

720

chiavi a bussola Macchina serie normale

12"



UNI/ISO 2725 DIN 3129

Ø mm	Ø mm	L mm	Ø1 mm	
8	15,0	38	25	5 007200008
9	16,0	38	25	5 007200009
10	17,0	38	25	5 007200010
11	18,5	38	25	5 007200011
12	20,0	38	25	5 007200012
13	21,0	38	25	5 007200013
14	22,5	38	25	5 007200014
15	23,0	38	30	5 007200015
16	25,0	38	30	5 007200016
17	26,0	38	30	5 007200017
18	27,5	38	30	5 007200018
19	28,5	38	30	5 007200019
21	31,0	38	30	5 007200021

Ø mm	Ø mm	L mm	Ø1 mm	
22	32,5	38	30	5 007200022
23	34,0	38	30	5 007200023
24	35,0	38	30	5 007200024
27	38,5	45	30	3 007200027
30	42,0	50	30	3 007200030
32	44,0	50	30	3 007200032
36	50,0	50	30	3 007200036

720AS

chiavi a bussola Macchina serie normale

12"



Ø mm	Ø mm	L mm	Ø1 mm	
3/8	17,0	38	25	2 007200210
7/16	18,2	38	25	2 007200211
1/2	20,7	38	25	2 007200213
9/16	22,0	38	25	2 007200214
5/8	24,5	38	30	2 007200216
11/16	25,7	38	30	2 007200217
3/4	28,2	38	30	2 007200219
13/16	30,7	38	30	2 007200221
7/8	32,0	38	30	2 007200222
15/16	34,5	38	30	2 007200224
1	35,7	38	30	2 007200225
1.1/16	38,2	40	30	1 007200227
1.1/8	40,7	42	30	1 007200229
1.1/4	44,5	42	30	1 007200232

720L

chiavi a bussola Macchina serie lunga

12"



UNI/ISO 2725

Ø mm	Ø mm	L mm	Ø1 mm	
10	17,0	80	25	2 007200310
11	18,5	80	25	2 007200311
12	20,0	80	25	2 007200312
13	21,0	80	25	2 007200313
14	22,5	80	25	2 007200314
15	23,0	80	30	2 007200315
16	25,0	80	30	2 007200316
17	26,0	80	30	2 007200317
18	27,5	80	30	2 007200318
19	28,5	80	30	2 007200319
21	31,0	80	30	2 007200321
22	32,5	80	30	2 007200322
24	35,0	80	30	2 007200324
27	38,5	80	30	2 007200327
30	42,0	80	30	2 007200330
32	44,0	80	30	2 007200332
36	50,0	80	30	2 007200336

720L/S3

serie di 3 chiavi a bussola 720L

12"



17-19-21 1 007200355

720LS

chiavi a bussola Macchina serie lunga sottile

12"



UNI/ISO 2725

Ø mm	Ø mm	L mm	Ø1 mm	
10	15,5	78	24	2 007200360
11	16,7	78	24	2 007200361
12	18,0	78	24	2 007200362
13	19,2	78	24	2 007200363
14	20,5	78	24	2 007200364
15	21,7	78	24	2 007200365
16	23,0	78	24	2 007200366
17	24,2	78	29	2 007200367
18	25,5	78	29	2 007200368
19	26,7	78	29	2 007200369
21	29,2	78	29	2 007200371
22	30,5	78	29	2 007200372
24	33,0	78	29	2 007200374
27	36,7	78	29	2 007200377
30	40,5	78	29	2 007200380
32	43,0	78	29	2 007200382
36	48,0	78	29	2 007200386

720LC

chiavi a bussola Macchina per dadi ruote con inserti polimerici colorati

12"



Ø mm	Ø mm		
17	26,5	Blue	2 007200637
19	28,5	Yellow	2 007200639
21	30,3	Red	2 007200641
22	32,4	Green	2 007200642
24	34,6	Purple	2 007200644

12"



720LC/C3 17-19-21 mm 1 007200653
148x132x44 mm - 860 g

12"



720LC/S5 17-19-21-22-24 mm 1 007200645

720IC

inserti di ricambio polimerici colorati per chiavi a bussola 720LC-720LCL



	mm			
720IC 17	17		1	007200687
720IC 19	19		1	007200689
720IC 21	21		1	007200691
720IC 22	22		1	007200692
720IC 24	24		1	007200694

720LCL

chiavi a bussola Macchina per dadi ruote con inserti polimerici colorati serie lunga



mm	Ø mm			
17	26,5		1	007200737
19	28,5		1	007200739
21	30,3		1	007200741



720LCL/C3				
17-19-21 mm			1	007200753
210x50x150 mm		-	1,65 kg	

720MRC

chiave a bussola Macchina con inserto polimerico per vite ruota con profilo Mercedes



mm	Ø mm	L mm		
17	27	85	1/2	1 007200631

Beta

720TC

barre di torsione Macchina colorate per dadi ruote autoveicoli con attacchi quadri maschio e femmina 1/2"



Nm	L mm			
90	200		1	007200769
100	200		1	007200770
110	200		1	007200771
120	200		1	007200772
135	200		1	007200773



720TC/S5				
90-100-110-120-135 Nm			1	007200779
260x50x175 mm		-	1,35 kg	

720FTX

chiavi a bussola Macchina per viti con testa a profilo Torx®



	Ø mm	L mm	Ø1 mm		
E10	14,0	38	25	2	007200410
E12	15,9	38	25	2	007200412
E14	17,7	38	25	2	007200414
E16	20,0	38	25	2	007200416
E18	22,0	38	25	2	007200418
E20	25,0	40	25	2	007200420
E24	30,0	40	30	2	007200424



720FTX/SB6				
E10-E12-E14-E16-E18-E20			1	007200450

720TX

chiavi a bussola maschio Macchina per viti con impronta Torx®



	Ø mm	L mm	L1 mm		
T30	25	78	54	3	007200460
T40	25	78	54	3	007200470
T45	25	78	54	3	007200472
T50	25	78	54	3	007200474
T55	25	78	54	3	007200476
T60	25	78	54	3	007200478

720TX/C6

6 chiavi a bussola maschio Macchina per viti con impronta Torx®



720TX/C6				
T30-T40-T45-T50-T55-T60			1	007200483

275x120x65 mm - 5700 g

720ME

chiavi a bussola Macchina maschio esagonale

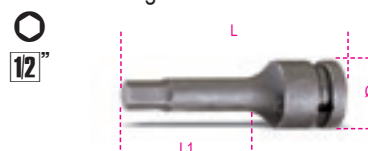

mm	Ø mm	L mm	L1 mm		
5	25	78	54	3	007200505
6	25	78	54	3	007200506
8	25	78	54	3	007200508
10	25	78	54	3	007200510
12	25	78	54	3	007200512
14	25	78	54	3	007200514
17	25	78	54	3	007200517
19	25	78	54	3	007200519

Beta

Beta

720ME/C8

8 chiavi a bussola Macchina
maschio esagonale

12"



720ME/C8
5-6-8-10-12
14-17-19 mm

1 007200525

270x120x45 mm - 1710 g

720/15

raccordo Macchina con attacco quadro
femmina 1/2" e maschio 3/8"

12"



L mm 37,5
Ø mm 25
□ 1/2
■ 3/8

3 007200810



E' assolutamente necessario commisurare la coppia di serraggio alla capacità del quadro maschio per evitare rotture o danni accidentali

720/16

raccordo Macchina con attacco quadro
femmina 1/2" e maschio 3/4"

12"



L mm 44
Ø mm 30
□ 1/2
■ 3/4

3 007200814

720/20

prolunga Macchina con attacchi quadri
maschio e femmina 1/2"

12"



L mm 75
Ø mm 25

3 007200818

720/21

prolunga Macchina con attacchi quadri
maschio e femmina 1/2"

12"



L mm 125
Ø mm 25

3 007200822

720/25

snodo Macchina con attacchi quadri
maschio e femmina 1/2"

12"



L mm 64
Ø mm 28

2 007200831

720/C6

6 chiavi a bussola Macchina

12"



720/C6
13-14-17-19-22-24 mm

1 007200910

195x80x55 mm - 1100 g

720/C12

12 chiavi a bussola Macchina

12"



720/C12
10-11-12-13-14-17
19-22-24-27-30-32 mm

1 007200912

195x80x55 mm - 2000 g

720/OR... - 720/SP...

anelli e spine per bussole e accessori
Macchina

12"

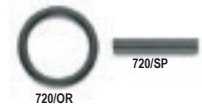

	720 mm	720TX T30-T60	
720/OR1	10-14		10 007200923
720/OR2	15-32		10 007200924
720/SP1	10-14	T30-T60	10 007200913
720/SP2	15-32		10 007200914

727PI/16

bussola portainseri Macchina
per 727/ES16 e 727/ES16TX

3/4"



Ø mm 44
L mm 52
□ mm 16
□ 3/4

2 007270016

727/ES16

inserti Macchina maschio esagonale,
attacco 16 mm

12"



mm	● mm	L mm	
10	16	40	2 007270110
12	16	40	2 007270112
13	16	40	2 007270113
14	16	40	2 007270114
16	16	40	2 007270116
17	16	40	2 007270117
18	16	40	2 007270118
19	16	40	2 007270119
22	16	40	2 007270122

727/ES16TX

inserti Macchina maschio per viti
con impronta Torx®, attacco 16 mm

12"



	● mm	L mm	
T55	16	50	2 007270355
T60	16	50	2 007270360
T70	16	50	2 007270370



727PI/22

bussola portainseri Macchina per 727/ES22 e 727/ES22TX



Ø mm	L mm	Ø mm	
54	70	22	2 007270022

727/ES22

inserti Macchina maschio esagonale, attacco 22 mm



mm	Ø mm	L mm	
19	22	50	2 007270219
22	22	50	2 007270222
24	22	50	2 007270224
27	22	50	2 007270227
30	22	50	2 007270230
32	22	50	2 007270232

727/ES22TX

inserti Macchina maschio per viti con impronta Torx®, attacco 22 mm



	Ø mm	L mm	
T80	22	60	2 007270480
T90	22	60	2 007270490
T100	22	60	2 007270500

727/C16

12 inserti Macchina maschio e 4 accessori



727/C16 1 007270900

- 727PI/16
- 727/ES16 14-17-19 mm
- 727/ES16TX T55-T60-T70
- 727PI/22
- 727/ES22 22-24-27 mm
- 727/ES22TX T80-T90-T100

96BPC 3-4 mm
335x145x60 mm - 3,6 kg

727PI/32

bussola portainseri Macchina per 727/ES32

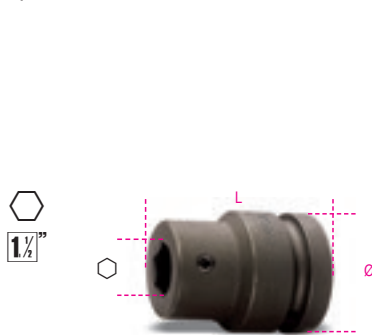

Ø mm	L mm	Ø mm	
86	66	32	1 007270032

727/ES32

inserti Macchina maschio esagonale, attacco 32 mm



mm	Ø mm	L mm	
19	32	44	2 007270519
22	32	44	2 007270522
24	32	44	2 007270524
27	32	44	2 007270527
30	32	44	2 007270530
32	32	44	2 007270532
36	32	44	2 007270536

728

chiavi a bussola Macchina serie normale



UNI/ISO 2725 DIN 3129

Ø mm	L mm	Ø1 mm	
17	30,0	51	44 2 007280017
18	31,0	51	44 2 007280018
19	32,5	51	44 2 007280019
21	35,0	51	44 2 007280021
22	36,0	51	44 2 007280022
23	37,5	51	44 2 007280023
24	38,5	51	44 2 007280024
27	42,5	53	44 2 007280027
28	44,0	53	44 2 007280028
30	46,0	53	44 2 007280030
32	48,5	57	44 2 007280032
33	50,0	57	44 2 007280033
34	51,0	57	44 2 007280034
35	52,5	57	44 2 007280035
36	53,5	57	44 2 007280036
38	56,0	57	44 1 007280038
40	58,5	58	44 1 007280040
41	60,0	58	44 1 007280041
44	64,0	62	44 1 007280044
45	65,0	62	44 1 007280045
46	66,0	62	44 1 007280046
50	71,0	68	54 1 007280050
55	77,5	71	54 1 007280055
60	83,0	73	54 1 007280060
65	88,0	78	54 1 007280065

728AS

chiavi a bussola Macchina serie normale

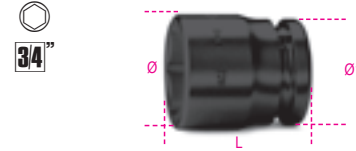

Ø mm	L mm	Ø1 mm	
3/4	32,0	51	41 1 007280219
13/16	35,0	51	41 1 007280221
7/8	36,0	51	41 1 007280222
15/16	38,5	51	41 1 007280224
1	40,0	53	41 1 007280225
1.1/16	42,5	53	44 1 007280227
1.1/8	44,0	53	44 1 007280230
1.1/4	48,5	57	44 1 007280232
1.5/16	50,0	57	44 1 007280233
1.7/16	53,5	57	44 1 007280236
1.1/2	56,0	57	44 1 007280238
1.5/8	60,0	58	44 1 007280241

728FTX

chiavi a bussola Macchina per viti con testa a profilo Torx®



Ø mm	L mm	Ø1 mm	
E20	28,5	50	44 2 007280420
E22	30,0	50	44 2 007280422
E24	32,5	50	44 2 007280424

728L

chiavi a bussola Macchina serie lunga



Ø mm	L mm	Ø1 mm	
19	32,5	90	44 2 007280319
21	35,0	90	44 2 007280321
22	36,0	90	44 2 007280322
24	38,5	90	44 2 007280324
26	41,0	90	44 2 007280326
27	42,5	90	44 2 007280327
30	46,0	90	44 2 007280330
32	48,5	90	44 2 007280332
33	50,0	90	44 1 007280333
34	51,0	90	44 1 007280334
36	53,5	90	44 1 007280336
38	56,0	90	44 1 007280338
41	60,0	90	44 1 007280341
44	64,0	90	44 1 007280344
46	66,0	90	44 1 007280346
50	71,0	90	44 1 007280350
55	77,5	100	54 1 007280355

728LS

chiavi a bussola Macchina serie lunga sottile



Ø mm	L mm	Ø1 mm	
17	28,0	100	43 2 007280517
19	30,5	100	43 2 007280519
22	34,3	100	43 2 007280522
24	36,8	100	43 2 007280524

mm	Ø mm	L mm	Ø1 mm		
27	40,5	100	43	2	007280527
30	44,3	100	43	2	007280530
32	46,8	100	43	2	007280532
33	48,0	100	43	2	007280533
36	51,8	100	43	1	007280536

728LQ

chiavi a bussola Macchina serie lunga
(per dadi ruote ISUZU)



mm	L mm	Ø mm	Ø1 mm		
19	90	35	43,5	1	007280619
21	90	42	43,5	1	007280621

728/15

raccordo Macchina con attacco quadro femmina 3/4" e maschio 1/2"

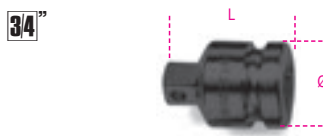

L mm	Ø mm	□	■		
58	38	3/4	1/2	2	007280810



E' assolutamente necessario commisurare la coppia di serraggio alla capacità del quadro maschio per evitare rotture o danni accidentali

728/16

raccordo Macchina con attacco quadro femmina 3/4" e maschio 1"



L mm	Ø mm	□	■		
62	44	3/4	1	2	007280813

728/21

prolunga Macchina con attacchi quadri maschio e femmina 3/4"



L mm	Ø mm		
175	44	2	007280815

728/22

prolunga Macchina con attacchi quadri maschio e femmina 3/4"



L mm	Ø mm		
250	44	2	007280825

728/22L

prolunga Macchina con attacchi quadri maschio e femmina 3/4"



L mm	Ø mm		
330	44	1	007280826

728/25

snodo Macchina con attacchi quadri maschio e femmina 3/4"



L mm	Ø mm		
107,5	44	1	007280830

728/C10

10 chiavi a bussola Macchina



728/C10		
17-19-22-24-27-30		1 007280910
32-36-41-46 mm		

275x120x65 mm - 5,7 kg

728/OR - 728/SP

anelli e spine per bussole e accessori Macchina



728/OR	728/SP	728FTX	
728/15	728/15		5 007280925
17+46	E20+E24		10 007280926
17+46	E20+E24		10 007280916

729

chiavi a bussola Macchina serie normale



UNI/ISO 2725 DIN 3129

mm	Ø mm	L mm	Ø1 mm		
24	41,5	58	54	1	007290024
27	45,0	60	54	1	007290027
30	49,0	62	54	1	007290030
32	51,5	63	54	1	007290032
33	52,5	63	54	1	007290033
34	54,0	63	54	1	007290034
36	56,5	66	54	1	007290036
38	59,0	66	54	1	007290038
41	62,5	68	54	1	007290041
46	69,0	72	54	1	007290046
50	74,0	76	54	1	007290050
55	80,0	84	54	1	007290055
60	86,5	88	54	1	007290060
65	92,5	92	54	1	007290065
70	99,0	96	54	1	007290070
75	105,0	102	63	1	007290075
80	111,5	102	63	1	007290080

729L

chiavi a bussola Macchina serie lunga



mm	Ø mm	L mm	Ø1 mm		
24	41,5	108	54	1	007290324
27	45,0	108	54	1	007290327
30	49,0	108	54	1	007290330
32	51,5	108	54	1	007290332
33	52,2	108	54	1	007290333
34	54,0	108	54	1	007290334
36	56,5	108	54	1	007290336
41	62,5	108	54	1	007290341
46	69,0	108	54	1	007290346
50	74,0	108	54	1	007290350
55	80,0	108	54	1	007290355
60	86,5	108	54	1	007290360
65	92,5	108	54	1	007290365
70	99,0	108	54	1	007290370
75	105,0	108	63	1	007290375
80	111,5	108	63	1	007290380

729LS

chiavi a bussola Macchina serie lunga sottile



mm	Ø mm	L mm	Ø1 mm		
22	36,0	108	53	1	007290522
24	38,5	108	53	1	007290524
27	42,3	108	53	1	007290527
30	46,0	108	53	1	007290530
32	48,5	108	53	1	007290532
33	49,8	108	53	1	007290533
36	53,5	108	53	1	007290536

729T

barre di torsione Macchina per dadi ruote



mm	Nm	L mm	
24	350	300	1 007290724
27	450	300	1 007290757
30	500	300	1 007290730
32	450	300	1 007290732
32	600	300	1 007290762
33	600	300	1 007290763
36	600	300	1 007290736

729/15

raccordo Macchina con attacco quadro femmina 1" e maschio 3/4"



L mm	Ø mm	□	■	
66,5	54	1	3/4	1 007290810



E' assolutamente necessario commisurare la coppia di serraggio alla capacità del quadro maschio per evitare rotture o danni accidentali

729/16

raccordo Macchina con attacco quadro femmina 1" e maschio 1.1/2"



L mm	Ø mm	□	■	
88	54,0	1	1.1/2	1 007290813

729/21

prolunga Macchina con attacchi quadri maschio e femmina 1"



L mm	Ø mm	
175	54	1 007290815

729/22

prolunga Macchina con attacchi quadri maschio e femmina 1"

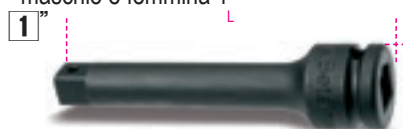

L mm	Ø mm	
330	54	1 007290825

729/25

snodo Macchina con attacchi quadri maschio e femmina 1"



L mm	Ø mm	
130	54	1 007290830

729/OR... - 729/SP...

anelli e spine per bussole e accessori Macchina



	728 mm	729-730 mm	
729/OR1	50+60	24+70	5 007290927
729/OR2		75+125	5 007290928
729/SP1	50+60	24+70	5 007290917
729/SP2		75+125	5 007290918

730

chiavi a bussola Macchina serie normale



UNI/ISO 2725 DIN 3129

mm	Ø mm	L mm	Ø1 mm	
50	81	87	84	1 007300050
55	88	90	86	1 007300055
60	94	95	86	1 007300060
65	100	100	86	1 007300065
70	106	105	86	1 007300070
75	113	110	86	1 007300075
80	119	115	86	1 007300080
85	125	120	86	1 007300085
90	132	125	86	1 007300090
95	138	125	96	1 007300095
100	144	130	96	1 007300100
105	150	135	96	1 007300105
110	157	140	96	1 007300110
115	163	140	96	1 007300115
120	169	145	96	1 007300120
125	175	145	96	1 007300125

730/15

raccordo Macchina riduttore



L mm	Ø mm	□	■	
105	84,0	1.1/2	1	1 007300810



E' assolutamente necessario commisurare la coppia di serraggio alla capacità del quadro maschio per evitare rotture o danni accidentali

733/15

raccordo Macchina riduttore



L mm	Ø mm	□	■	
156	127	2.1/2	1.1/2	1 007330810

851

portainserti magnetico con impugnatura

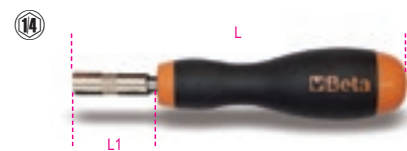

L1 mm	L mm	
45	165	2 008510165
125	245	2 008510245

851SR

portainserti a sgancio rapido con impugnatura



L mm	L1 mm	
230	110	2 008510001

852

portainserti a T snodato

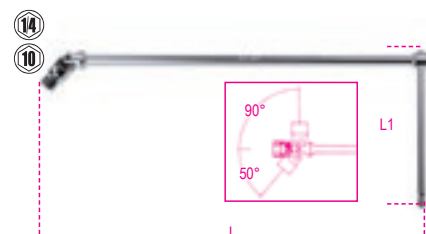

□	L mm	L1 mm	
1/4"	400	160	2 008520006
10 mm	400	160	2 008520010

895

bussole portainseri
per 860, 861, 862, 866



DIN 7427

	□	○	L	Ø		
	mm	mm	mm	mm		
895/1	1/4	1/4	25,4	12	5	008950000
895/3	1/4	3/8	29	16,8	5	008950001
895/4	5/16	3/8	29	16,8	5	008950002
895/5	1/4	1/2	38	22	5	008950005
895/6	5/16	1/2	38	22	5	008950003

897

portainseri flessibile
con impugnatura



L	L1		
mm	mm		
280	154	2	008970010

897L

portainseri flessibile con impugnatura
modello lungo



L	L1		
mm	mm		
500	380	2	008970015

900

chiavi a bussola a mano
bocca esagonale



UNI/ISO 2725 DIN 3124

⊗	Ø	L	Ø1		
mm	mm	mm	mm		
4	6,8	25	11,8	10	009000040
4,5	7,4	25	11,8	10	009000045
5	8,0	25	11,8	10	009000050
5,5	8,7	25	11,8	10	009000055
6	9,3	25	11,8	10	009000060
7	10,4	25	11,8	10	009000070
8	11,8	25	12,7	10	009000080
9	12,7	25	11,8	10	009000090
10	14,2	25	12,0	10	009000100
11	15,8	25	12,5	10	009000110
12	17,2	25	13,5	10	009000120
13	18,0	25	13,5	10	009000130
14	20,0	25	15,0	10	009000140



900/SB13	
4-4,5-5-5,5-6-7-8-9	1 009000150
10-11-12-13-14 mm	

900MB

chiavi a bussola a mano
bocca poligonale



UNI/ISO 2725 DIN 3124

⊗	Ø	L	Ø1		
mm	mm	mm	mm		
4	6,7	22	11,2	5	009000160
5	7,7	25	11,2	5	009000161
5,5	8,3	25	11,2	5	009000162
6	9,0	25	11,2	5	009000163
7	10,2	25	11,2	5	009000164
8	11,3	25	12,0	5	009000165
9	13,0	25	12,0	5	009000166
10	14,3	25	12,9	5	009000167
11	16,0	25	14,3	5	009000168
12	17,4	25	16,0	5	009000169
13	18,0	25	16,4	5	009000170
14	19,3	25	17,9	5	009000171



900MB/SB12	
4-5-5,5-6-7-8-9-10	1 009000179
11-12-13-14 mm	

900L

chiavi a bussola a mano lunghe
bocca esagonale



UNI/ISO 2725 DIN 3124

⊗	Ø	L	Ø1		
mm	mm	mm	mm		
4	6,5	50	12,0	5	009000181
4,5	7,0	50	12,0	5	009000182
5	7,5	50	12,0	5	009000183
5,5	8,5	50	12,0	5	009000184
6	9,5	50	12,0	5	009000185
7	10,5	50	12,0	5	009000186
8	12,0	50	12,0	5	009000187
9	13,0	50	13,0	5	009000188
10	14,0	50	14,0	5	009000189
11	16,0	50	16,0	5	009000190
12	17,5	50	17,5	5	009000191
13	17,5	50	17,5	5	009000192
14	20,0	50	20,0	5	009000193



900L/SB13	
4-4,5-5-5,5-6-7-8-9-10-11-12-13-14 mm	1 009000203

900MB/L

chiavi a bussola a mano lunghe
bocca poligonale



UNI/ISO 2725 DIN 3124

⊗	Ø	L	Ø1		
mm	mm	mm	mm		
5	8,0	50	12,0	3	009000211
6	9,3	50	12,0	3	009000212
7	10,9	50	12,0	3	009000213
8	11,6	50	12,0	3	009000214
9	13,0	50	12,0	3	009000215
10	14,3	50	12,8	3	009000216
11	16,0	50	14,2	3	009000217
12	17,4	50	15,5	3	009000218
13	18,0	50	16,2	3	009000219
14	19,0	50	17,1	3	009000220

900AS

chiavi a bussola a mano
bocca esagonale



⊗	Ø	L	Ø1		
mm	mm	mm	mm		
5/32	8,8	25	11,9	5	009000349
3/16	7,7	25	11,9	5	009000340
7/32	8,8	25	11,9	5	009000345
1/4	9,6	25	11,9	5	009000350
9/32	10,2	25	11,9	5	009000355
5/16	11,3	25	11,9	5	009000360
11/32	12,7	25	11,6	5	009000365
3/8	14,0	25	12,9	5	009000370
7/16	15,3	25	14,5	5	009000375
1/2	17,5	25	16,4	5	009000380
9/16	19,0	25	17,9	5	009000385



900AS/SB11	
3/16-7/32-5/32-1/4-9/32-5/16-11/32-3/8-7/16-1/2-9/16	1 009000389

900AS/MB

chiavi a bussola a mano
bocca poligonale



SAE AS 954E

⊗	Ø	L	Ø1		
"	mm	mm	mm		
3/16	7,7	22	10,9	2	009000390
7/32	8,5	22	10,9	2	009000391
1/4	9,4	22	10,9	2	009000392
9/32	10,2	22	10,9	2	009000393
5/16	11,3	22	11,7	2	009000394
11/32	12,5	22	12,0	2	009000395
3/8	13,7	22	12,9	2	009000396
7/16	15,6	22	14,3	2	009000397
1/2	17,2	22	16,4	2	009000398
9/16	18,8	24	17,9	2	009000399

900AS/L

chiavi a bussola a mano lunghe
bocca esagonale



SAE AS 954E

"	Ø mm	L mm	Ø1 mm		
3/16	7,0	50	12,0	2	009000301
7/32	8,5	50	12,0	2	009000303
1/4	9,8	50	12,0	2	009000305
9/32	10,5	50	12,0	2	009000307
5/16	12,0	50	12,0	2	009000309
11/32	13,0	50	13,0	2	009000311
3/8	14,0	50	14,0	2	009000313
7/16	16,0	50	16,0	2	009000315
1/2	17,5	50	17,5	2	009000317
9/16	20,0	50	20,0	2	009000319

900AS/MBL

chiavi a bussola a mano lunghe
bocca poligonale



"	Ø mm	L mm	Ø1 mm		
5/32	6,8	50	12,0	2	009000325
3/16	8,0	50	12,0	2	009000326
7/32	8,5	50	12,0	2	009000327
1/4	9,8	50	12,0	2	009000328
9/32	10,9	50	12,0	2	009000329
5/16	11,6	50	12,0	2	009000330
11/32	13,0	50	12,0	2	009000331
3/8	14,3	50	12,8	2	009000332
7/16	16,0	50	14,2	2	009000333
1/2	18,0	50	16,2	2	009000334
9/16	19,0	50	17,1	2	009000335

900FTX

chiavi a bussola a mano per viti
con teste a profilo Torx®

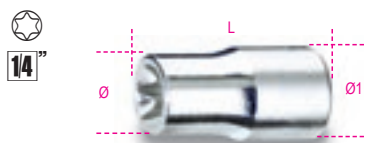

"	Ø mm	L mm	Ø1 mm		
E4	5,4	22	11,2	5	009000404
E5	6,7	22	11,2	5	009000405
E6	7,7	22	11,2	5	009000406
E7	8,3	22	11,2	5	009000407
E8	9,6	22	11,2	5	009000408
E10	11,3	22	12,0	5	009000410
E11	12,1	22	12,5	5	009000411
E12	12,9	23	12,9	5	009000412
E14	14,0	25	14,0	5	009000414



900FTX/SB9
E4-E5-E6-E7-E8
E10-E11-E12-E14

900LP

chiavi a bussola a giravite
per viti con intaglio



SxA mm	Ø mm	L mm	L1 mm		
0,8x4	12	28	9	5	009000605
1x5,5	12	28	9	5	009000610
1,2x6,5	12	28	9	5	009000615
1,2x8	13	28	8	5	009000620
1,6x10	14	28	8	5	009000625

900PH

chiavi a bussola a giravite
per viti con impronta a croce Phillips®



PH	Ø mm	L mm	L1 mm		
1	12	28	12	5	009000701
2	12	28	12	5	009000702
3	12	28	12	5	009000703
4	13	28	11	5	009000704



900PH/SB4
PH1-PH2-PH3-PH4

900ME

chiavi a bussola a giravite
maschio esagonale



mm	Ø mm	L mm	L1 mm		
2,5	12	25	4,5	5	009000502
3	12	25	5,0	5	009000503
4	12	25	5,6	5	009000504
5	12	25	6,3	5	009000505
6	12	25	7,6	5	009000506
7	13	25	7,2	5	009000507
8	13	25	8,0	5	009000508
10	13	25	8,7	5	009000510



900ME/SB8
2,5-3-4-5-6-7-8-10 mm

900PT

chiavi a bussola a giravite per viti con
impronta pentalobata



"	Ø mm	L mm	L1 mm		
PT10	12	28	12	5	009000750
PT15	12	28	12	5	009000755
PT20	12	28	12	5	009000760
PT25	12	28	12	5	009000765
PT27	12	28	12	5	009000767
PT30	12	28	12	5	009000770

900TX

chiavi a bussola a giravite maschio
per viti con impronta Torx®



"	Ø mm	L mm	L1 mm		
T8	12	28	12	5	009000719
T9	12	28	12	5	009000720
T10	12	28	12	5	009000721
T15	12	28	12	5	009000722
T20	12	28	12	5	009000723
T25	12	28	12	5	009000724
T27	12	28	12	5	009000725
T30	12	28	12	5	009000726
T40	12	28	12	5	009000727



900TX/SB8
T9-T10-T15-T20
T25-T27-T30-T40

900/16

raccordo con attacco quadro
femmina 1/4" e maschio 3/8"



UNI/ISO 3316 DIN 3123

L mm	Ø mm				
28	13,0	1/4	3/8	5	009000814

900/...

prolunghe con attacchi quadri maschio e femmina 1/4"

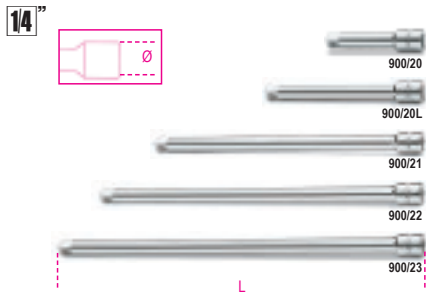

UNI/ISO 3316 DIN 3123

	L mm	Ø mm	
900/20	50	11,5	5 009000818
900/20L	100	11,5	5 009000819
900/21	150	11,5	5 009000822
900/22	250	11,5	5 009000823
900/23	350	11,5	5 009000824

900AN

prolunghe con attacchi quadri maschio e femmina 1/4" angolari

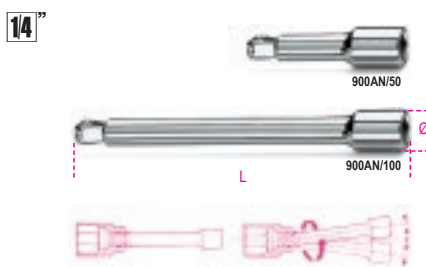

	L mm	Ø mm	
900AN/50	50	11,5	3 009000825
900AN/100	100	11,5	3 009000826

900FL

prolunga flessibile con attacchi quadri maschio e femmina 1/4"



L mm	Ø mm	
150	12	3 009000828

900/25

snodo con attacchi quadri maschio e femmina 1/4"



UNI/ISO 3316 DIN 3123

L mm	Ø mm	
41	12,5	5 009000830

900BG/30C

quadro maschio 1/4" con impugnatura



UNI/ISO 3315 DIN 3122

L mm	L1 mm	
128	20	5 009000833

900BG/30

quadro maschio 1/4" con impugnatura



UNI/ISO 3315 DIN 3122

L mm	L1 mm	
176	68	5 009000834

900/32

quadro maschio 1/4" flessibile con impugnatura



L mm	L1 mm	
280	154	2 009000839

900/35A

quadro maschio 1/4" snodato con impugnatura



UNI/ISO 3315 DIN 3122

L mm	L1 mm	
148	84	5 009000840

900M/35

quadro maschio 1/4" snodato con impugnatura in metallo

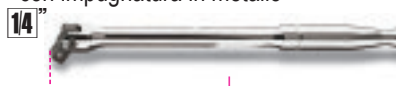

UNI/ISO 3315
DIN 3122

L mm		
130		3 009000845

900/40

quadro maschio 1/4" snodato a T



L mm	L1 mm	
390	145	3 009000843

900/42

quadro maschio 1/4" con spina scorrevole



UNI/ISO 3315 DIN 3122

L mm	A mm	
115	22	5 009000854

900T/44

quadro maschio 1/4" piegato con impugnatura di manovra



L mm	L1 mm	
238	105	2 009000860

900/55

cricchetto reversibile con attacco quadro maschio 1/4" meccanismo a 48 denti



UNI/ISO 3315 DIN 3122

L mm	Ø mm	A mm	
125	25	18	5 009000870

900M/55

cricchetto reversibile con attacco quadro maschio 1/4" con impugnatura in metallo



UNI/ISO 3315
DIN 3122

L mm	Ø mm	A mm	
110	22	18	3 009000905

**Meccanismi rotanti
di ricambio dei cricchetti,
vedi tabella dopo l'art. 929/C8**

900/58

cricchetto reversibile
con impugnatura rotante
con attacco quadro maschio 1/4"
meccanismo a 52 denti

- Pulsante di rilascio della bussola
- Sistema di inversione a ghiera sulla testa del cricchetto
- Impugnatura bimateriale



L mm	Ø mm	A mm	1	009000884
126	28	28,5	2	009000884

900/C39

11 chiavi a bussola esagonali, 21 inserti e 7 accessori



900/C39 1 009000937

861LP	0,6x4,5 - 1,2x6,5 - 1,2x8 mm
861PH	PH1-PH2-PH3
861PZ	PZ1-PZ2-PZ3
861PE	2,5-3-4-5-6 mm
861RTX	T10-T15-T20-T25-T27-T30-T40
900	5-5,5-6-7-8-9-10-11-12-13-14 mm
900/20	50 mm
900/20L	100 mm
900/25	
900BG/30C	
900/55	
892/0	
895/1	

900/C11

11 chiavi a bussola esagonali,
20 inserti per avvitatori e 8 accessori



900/C11 1 009000971

861LP	0,5x3 - 0,8x5,5 1x5,5 - 1,2x6,5 mm
861PE	3 - 4 - 5 - 6 - 8 mm
861PH	0 - 1 - 2 - 3
861TX	T8 - T10 - T15 - T20 T25 - T30 - T40
895/1	
900	5 - 5,5 - 6 - 7 - 8 - 9 - 10 11 - 12 - 13 - 14 mm
900/16	□ 1/4 - ■ 3/8
900/20	50 mm
900/21	150 mm
900/25	
900BG/30	
900/42	
900/55	

270x120x45 mm - 1,2 kg

900/C13-5

13 chiavi a bussola esagonali
e 5 accessori



900/C13-5 1 009000953

900	4 - 4,5 - 5 - 5,5 - 6 - 7 - 8 - 9 10 - 11 - 12 - 13 - 14 mm
900/21	150 mm
900/25	
900BG/30	
900/42	
900/55	

270x120x45 mm - 1 kg

900/C13-8

13 chiavi a bussola esagonali
e 8 accessori



900/C13-8 1 009000954

900	4 - 4,5 - 5 - 5,5 - 6 - 7 - 8 - 9 10 - 11 - 12 - 13 - 14 mm
900/16	□ 1/4 - ■ 3/8
900/20	50 mm
900/21	150 mm
900/25	
900BG/30	
900/35A	
900/42	
900/55	

270x120x45 mm - 1,1 kg

900MB/C19

11 chiavi a bussola poligonali
e 8 accessori



900MB/C19 1 009000977

900MB	5 - 5,5 - 6 - 7 - 8 - 9 - 10 - 11 12 - 13 - 14 mm
900/16	□ 1/4 - ■ 3/8
900/20	50 mm
900/21	150 mm
900/25	
900BG/30	
900/35A	
900/42	
900/55	

270x120x45 mm - 1,1 kg

900/C24

13 chiavi a bussola esagonali
11 a giravite e 6 accessori

1/4"



900/C24

1 009000956

	○ 900	4 - 4,5 - 5 - 5,5 - 6 - 7 - 8 - 9 10 - 11 - 12 - 13 - 14 mm
	● 900LP	0,8x4 - 1,2x6,5 - 1,2x8 mm
	⊕ 900PH	PH1 - PH2 - PH3
	○ 900ME	3 - 4 - 5 - 6 - 8 mm
	900/20	50 mm
	900/21	150 mm
	900/25	
	900BG/30	
	900/42	
	⊕ 900/55	
270x120x45 mm - 1,1 kg		

900MB/C28

11 chiavi a bussola poligonali
11 a giravite e 6 accessori

1/4"



900MB/C28

1 009000979

	○ 900MB	5 - 5,5 - 6 - 7 - 8 - 9 - 10 - 11 12 - 13 - 14 mm
	● 900LP	0,8x4 - 1,2x6,5 - 1,2x8 mm
	⊕ 900PH	PH1 - PH2 - PH3
	○ 900ME	3 - 4 - 5 - 6 - 8 mm
	900/20	50 mm
	900/21	150 mm
	900/25	
	900BG/30	
	900/42	
	⊕ 900/55	
270x120x45 mm - 1,1 kg		

900AS/C10 - /MB-C17

10 chiavi a bussola
e 7 accessori

1/4"



900AS/C10

1 009000961

	○ 900AS	3/16 - 7/32 - 1/4 - 9/32 - 5/16 11/32 - 3/8 - 7/16 - 1/2 - 9/16
	900/20	50 mm
	900/21	150 mm
	900/25	
	900BG/30	
	900/35A	
	900/42	
	⊕ 900/55	
270x120x45 mm - 1,1 kg		

900AS/MB-C17

1 009000981

	○ 900AS/MB	3/16 - 7/32 - 1/4 - 9/32 - 5/16 11/32 - 3/8 - 7/16 - 1/2 - 9/16
	900/20	50 mm
	900/21	150 mm
	900/25	
	900BG/30	
	900/35A	
	900/42	
	⊕ 900/55	
270x120x45 mm - 1,1 kg		

900AS/C17-MBM

10 chiavi a bussola poligonali
e 7 accessori
per manutenzioni aeronautiche

1/4"



900AS/C17-MBM

1 009000982

	○ 900AS/MB	3/16 - 7/32 - 1/4 - 9/32 - 5/16 11/32 - 3/8 - 7/16 - 1/2 - 9/16
	900/20	50 mm
	900/21	150 mm
	900/25	
	900BG/30	
	900M/35	
	900/42	
	900M/55	
270x120x45 mm - 1,2 kg		

900/C11HR

11 chiavi a bussola esagonali,
20 inserti per avvitatori e 7 accessori
in termoformato rigido,
in cassetta di lamiera

• cricchetto con impugnatura rotante

1/4"

1/4"



900/C11HR

1 009000980

	● 861LP	0,5x3-0,8x5,5-1x5,5-1,2x6,5 mm
	⊕ 861PH	PH0-PH1-PH2-PH3
	○ 861PE	3-4-5-6-8 mm
	⊕ 861TX	T8-T10-T15-T20-T25-T30-T40
	895/1	
	○ 900	5-5,5-6-7-8-9-10-11-12-13-14 mm
	900/16	□ 1/4 - ■ 3/8
	900/20	50 mm
	900/21	150 mm
	900/25	
	900/42	
	900/30	
	900/58	
350x150x50 mm - 1,3 kg		

902R/C6

6 raccordi per chiavi a bussola



902R/C6

1 009020814

	900/16	□ 1/4 - ■ 3/8
	910/15	□ 3/8 - ■ 1/4
	910/16	□ 3/8 - ■ 1/2
	920/15	□ 1/2 - ■ 3/8
	920/16	□ 1/2 - ■ 3/4
	928/15	□ 3/4 - ■ 1/2
170x100x35 mm - 600 g		

910A

chiavi a bussola a mano
bocca esagonale



UNI/ISO 2725 DIN 3124

mm	Ø	L	Ø1		
6	9,5	28	16,7	5	009100006
7	10,7	28	16,7	5	009100007
8	12,1	28	16,7	5	009100008
9	13,2	28	16,7	5	009100009
10	14,6	29	16,7	5	009100010
11	15,8	29	16,7	5	009100011
12	17,2	30	17,7	5	009100012
13	18,4	31	17,0	5	009100013
14	19,7	32	17,5	5	009100014
15	20,9	32	18,0	5	009100015
16	22,2	33	18,5	5	009100016
17	23,2	33	19,0	5	009100017
18	24,7	34	20,0	5	009100018
19	25,8	35	21,0	5	009100019
20	27,2	35	22,0	5	009100020
21	28,2	36	23,0	5	009100021
22	29,7	37	24,0	5	009100022



910A/SB17

6-7-8-9-10-11-12
13-14-15-16-17
18-19-20-21-22 mm

1 009100030

910B

chiavi a bussola a mano
bocca poligonale



UNI/ISO 2725 DIN 3124

mm	Ø	L	Ø1		
6	9,5	28	16,7	5	009100106
7	10,7	28	16,7	5	009100107
8	12,1	28	16,7	5	009100108
9	13,2	28	16,7	5	009100109
10	14,6	29	16,7	5	009100110
11	15,8	29	16,7	5	009100111
12	17,2	30	17,7	5	009100112
13	18,4	31	17,0	5	009100113
14	19,7	32	17,5	5	009100114
15	20,9	32	18,0	5	009100115
16	22,2	33	18,5	5	009100116
17	23,2	33	19,0	5	009100117
18	24,7	34	20,0	5	009100118
19	25,8	35	21,0	5	009100119
20	27,2	35	22,0	5	009100120
21	28,2	36	23,0	5	009100121
22	29,7	37	24,0	5	009100122



910B/SB17

6-7-8-9-10-11-12
13-14-15-16-17
18-19-20-21-22 mm

1 009100130

910AL

chiavi a bussola a mano lunghe
bocca esagonale



UNI/ISO 2725 DIN 3124

mm	Ø	L	Ø1		
8	12,0	55	17	3	009100158
9	13,0	55	17	3	009100159
10	14,5	55	17	3	009100160
11	16,0	55	17	3	009100161
12	17,0	55	17	3	009100162
13	18,0	55	17	3	009100163
14	20,0	55	18	3	009100164
15	21,0	55	20	3	009100165
16	22,0	55	20	3	009100166
17	23,5	55	22	3	009100167
18	24,5	55	23	2	009100168
19	25,0	55	24	2	009100169
21	27,0	65	26	2	009100171
22	29,0	65	28	2	009100172



910AL/SB14

8-9-10-11-12-13-14
15-16-17-18-19-21-22 mm

1 009100174

910BL

chiavi a bussola a mano lunghe
bocca poligonale



UNI/ISO 2725 DIN 3124

mm	Ø	L	Ø1		
8	12,0	55	17	3	009100308
9	13,0	55	17	3	009100309
10	14,5	55	17	3	009100310
11	16,0	55	17	3	009100311
12	17,0	55	17	3	009100312
13	18,0	55	17	3	009100313
14	20,0	55	18	3	009100314
15	21,0	55	20	3	009100315
16	22,0	55	20	3	009100316
17	23,5	55	22	3	009100317
18	24,5	55	23	2	009100318
19	25,0	55	24	2	009100319
21	27,0	65	26	2	009100321
22	29,0	65	28	2	009100322



910BL/SB14

8-9-10-11-12-13
14-15-16-17-18
19-21-22 mm

1 009100340

910B/SN

chiavi a bussola a mano snodate
bocca poligonale



mm	Ø	L	Ø1		
10	14,5	48,5	19	2	009100230
11	15,8	49,5	19	2	009100231
12	17,0	50,0	19	2	009100232
13	18,3	51,0	19	2	009100233
14	19,5	51,0	19	2	009100234
15	20,8	53,5	19	2	009100235
16	22,0	53,5	19	2	009100236
17	23,3	54,5	19	2	009100237
18	24,5	54,5	19	2	009100238
19	25,8	56,5	19	2	009100239

910A/AS

chiavi a bussola a mano
bocca esagonale

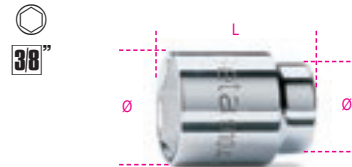

"	Ø	L	Ø1		
1/4	10,3	26	17,3	5	009100276
5/16	11,9	26	17,3	5	009100278
11/32	13,3	26	17,3	5	009100279
3/8	13,9	26	17,3	5	009100280
7/16	15,8	26	17,3	5	009100281
1/2	17,9	26	17,3	5	009100283
9/16	19,5	27	18,5	5	009100284
19/32	20,6	27	19,5	5	009100285
5/8	21,9	28	20,0	5	009100286
11/16	24,6	30	22,5	5	009100287
3/4	25,9	30	23,5	5	009100289
13/16	27,9	32	26,0	5	009100291
7/8	29,6	32	26,5	5	009100292



910A-AS/SB13

1/4-5/16-11/32-3/8-7/16
1/2-9/16-19/32-5/8-11/16
3/4-13/16-7/8

1 009100295

Beta

910AS

chiavi a bussola a mano
bocca poligonale

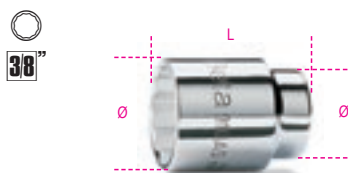

Size	Ø mm	L mm	Ø1 mm	Qty	Part No.
1/4	9,5	28	16,7	5	009100201
5/16	12,1	28	16,7	5	009100202
11/32	13,2	28	16,7	5	009100203
3/8	14,6	29	16,7	5	009100204
7/16	15,8	29	16,7	5	009100205
1/2	18,4	31	17,0	5	009100206
9/16	19,7	32	17,5	5	009100207
19/32	20,9	32	18,0	5	009100208
5/8	22,2	33	18,5	5	009100209
11/16	24,7	34	20,0	5	009100210
3/4	25,8	35	21,0	5	009100211
13/16	28,2	36	23,0	5	009100212
7/8	29,7	37	24,0	5	009100213



910AS/SB13
1/4-5/16-11/32-3/8-7/16
1/2-9/16-19/32-5/8-11/16
3/4-13/16-7/8
1 009100215

910AS/L

chiavi a bussola a mano lunghe
bocca poligonale

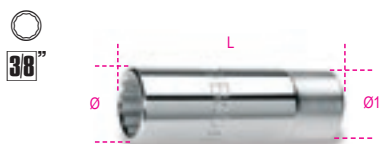

Size	Ø mm	L mm	Ø1 mm	Qty	Part No.
1/4	10	55	17	3	009100350
5/16	12	55	17	3	009100351
3/8	14	55	17	3	009100352
7/16	16	55	17	3	009100353
1/2	18	55	17	3	009100354
9/16	20	55	18	3	009100355
19/32	21	55	20	3	009100356
5/8	22	55	20	3	009100357
11/16	23	55	22	3	009100359
3/4	25	55	24	3	009100360
13/16	27	65	26	3	009100362
7/8	29	65	28	3	009100363



910ASL/SB12
1/4-5/16-3/8-7/16
1/2-9/16-19/32-5/8-11/16
3/4-13/16-7/8
1 009100365

910AS/SN

chiavi a bussola a mano snodate
bocca poligonale

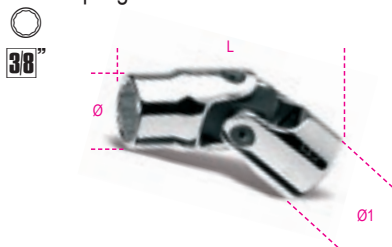

* SAE AS 954E

Size	Ø mm	L mm	Ø1 mm	Qty	Part No.
* 3/8	14,0	48,0	19	2	009100260
* 7/16	15,8	51,0	19	2	009100261
* 1/2	18,3	51,0	19	2	009100262
* 9/16	19,5	51,0	19	2	009100263
* 5/8	22,0	53,5	19	2	009100264
11/16	24,5	54,5	19	2	009100265
3/4	25,8	56,5	19	2	009100266

910FTX

chiavi a bussola a mano per viti
con testa a profilo Torx®



Size	Ø mm	L mm	Ø1 mm	Qty	Part No.
E4	6,2	26	17,3	5	009100404
E5	7,0	26	17,3	5	009100405
E6	8,3	26	17,3	5	009100406
E7	8,9	26	17,3	5	009100407
E8	9,9	26	17,3	5	009100408
E10	12,0	26	17,3	5	009100410
E12	14,5	26	17,3	5	009100412
E14	15,8	26	17,3	5	009100414
E16	18,0	26	17,3	5	009100416



910FTX/SB9
E4-E5-E6-E7-E8
E10-E12-14-E16
1 009100430

910FTX/L

chiavi a bussola a mano lunghe
per viti con testa a profilo Torx®



Size	Ø mm	L mm	Ø1 mm	Qty	Part No.
E4	6,2	55	17,3	3	009100440
E5	7,0	55	17,3	3	009100441
E6	8,3	55	17,3	3	009100442
E7	8,9	55	17,3	3	009100443
E8	9,9	55	17,3	3	009100444
E10	12,0	55	17,3	3	009100445



910FTX-L/SB6
E4-E5-E6
E7-E8-E10
1 009100449

910LP

chiavi a bussola a giravite
per viti con intaglio



Size	SxA mm	Ø mm	L mm	L1 mm	Qty	Part No.
1x5,5	18,5	18,5	54	24	2	009100452
1,2x6,5	18,5	18,5	54	24	2	009100453
1,2x8	18,5	18,5	54	24	2	009100454
1,6x9	18,5	18,5	54	24	2	009100456

910PH

chiavi a bussola a giravite
per viti con impronta a croce Phillips®



Size	PH	Ø mm	L mm	L1 mm	Qty	Part No.
1	1	18,5	48	18	2	009100471
2	2	18,5	48	18	2	009100472
3	3	18,5	48	18	2	009100473
4	4	18,5	48	18	2	009100474



910PH/SB4
PH1-PH2-PH3-PH4
1 009100478

910PE

chiavi a bussola maschio esagonale

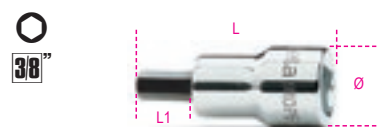

DIN 7422

Size	mm	Ø mm	L mm	L1 mm	Qty	Part No.
3	3	18,5	50	20	5	009100490
4	4	18,5	50	20	5	009100492
5	5	18,5	50	20	5	009100494
6	6	18,5	50	20	5	009100496
7	7	18,5	50	20	5	009100497
8	8	18,5	50	20	5	009100498
10	10	18,5	50	20	5	009100500



910PE/SB7
3-4-5-6-7-8-10 mm
1 009100503

910BP

chiavi a bussola maschio esagonale con estremità sferica



mm	L mm	L1 mm		
4L	92	62	3	009100584
5L	92	62	3	009100585
6L	92	62	3	009100586
7L	92	62	3	009100587
8L	92	62	3	009100588
10L	132	102	3	009100590



910BP/SB6L
4L-5L-6L-7L-8L-10L mm

910ME

chiavi a bussola maschio esagonale



mm	Ø mm	L mm	L1 mm		
4	18	62	15	5	009100504
5	18	62	15	5	009100505
6	18	62	15	5	009100506
7	18	62	15	5	009100507
8	19	62	15	5	009100508
10	20	62	15	5	009100510
12	20	62	15	5	009100512



910ME/SB5
4-5-6-8-10 mm

910PT

chiavi a bussola a giravite per viti con impronta pentalobata



PT	Ø mm	L mm	L1 mm		
PT40	20	50	20	3	009100540
PT45	20	50	20	3	009100545
PT50	20	50	20	3	009100550



910PT/SB8
PT10-PT15-PT20-PT25
PT30-PT40-PT45-PT50

910TX

chiavi a bussola maschio per viti con impronta Torx®



TX	Ø mm	L mm	L1 mm		
T15	18,5	50	20	5	009100519
T20	18,5	50	20	5	009100520
T25	18,5	50	20	5	009100521
T27	18,5	50	20	5	009100522
T30	18,5	50	20	5	009100523
T40	18,5	50	20	5	009100524



910TX/SB6
T15-T20-T25
T27-T30-T40

910CF

chiavi a zampa di gallo



CF	A mm	L mm		
10	21,3	32,3	2	009100135
11	23,1	34,3	2	009100136
12	25,5	36,2	2	009100137
13	26,9	37,4	2	009100138
14	30,2	40,0	2	009100139
15	33,3	41,3	2	009100140
16	33,3	41,3	2	009100141
17	38,1	46,5	2	009100142
18	38,1	46,5	2	009100143
19	39,6	48,0	2	009100144



910CF/SB10
10-11-12-13-14-15
16-17-18-19 mm

910/15

raccordo con attacco quadro femmina 3/8" e maschio 1/4"



UNI/ISO 3316 DIN 3123

L mm	Ø mm	□	■		
30	17,0	3/8	1/4	5	009100810



E' assolutamente necessario commisurare la coppia di serraggio alla capacità del quadro maschio per evitare rotture o danni accidentali

910/16

raccordo con attacco quadro femmina 3/8" e maschio 1/2"



UNI/ISO 3316 DIN 3123

L mm	Ø mm	□	■		
32	18,0	3/8	1/2	5	009100814

910/20 - 910/21 - 910/22

prolunghe con attacchi quadri maschio e femmina 3/8"

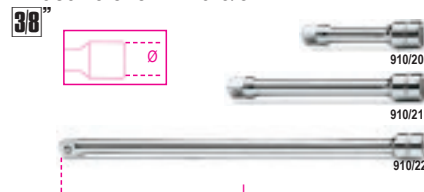

UNI/ISO 3316 DIN 3123

	L mm	Ø mm		
910/20	75	17	5	009100820
910/21	125	17	5	009100822
910/22	250	17	5	009100826

910AN

prolunghe con attacchi quadri maschio e femmina 3/8" angolari

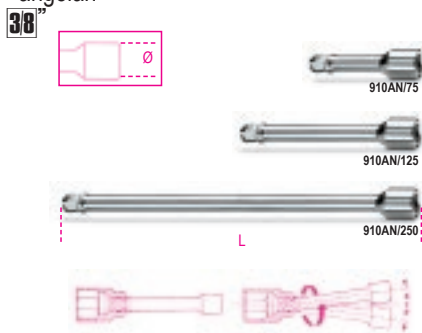

	L mm	Ø mm	
910AN/75	75	17	3 009100827
910AN/125	125	17	3 009100828
910AN/250	250	17	3 009100829

910/25

snodo con attacchi quadri maschio e femmina 3/8"



UNI/ISO 3316 DIN 3123

L mm	Ø mm	
54,6	19	5 009100830

910M/35

quadro maschio 3/8" snodato con impugnatura in metallo



UNI/ISO 3315 DIN 3122

L mm		
250		3 009100839

910/36A

quadro maschio 3/8" snodato con impugnatura



UNI/ISO 3315 DIN 3122

L mm	L1 mm	
255	154	3 009100845

910/40

quadro maschio 3/8" snodato a T



L mm	L1 mm	
420	175	3 009100850

910/42

quadro maschio 3/8" con spina scorrevole

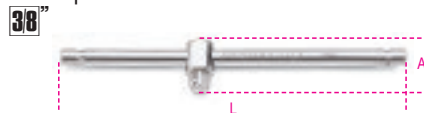

UNI/ISO 3315 DIN 3122

L mm	A mm	
210	30,5	5 009100854

910/46

quadro maschio 3/8" con manovella

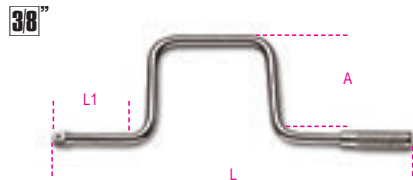

UNI/ISO 3315 DIN 3122

L mm	L1 mm	A mm	
315	80	115	1 009100862

910/55

cricchetto reversibile con attacco quadro maschio 3/8" meccanismo a 72 denti



UNI/ISO 3315 DIN 3122

L mm	Ø mm	A mm	
200	30	33	3 009100882

910/55Q

cricchetto reversibile con attacco quadro maschio 3/8" meccanismo a 48 denti



UNI/ISO 3315 DIN 3122

L mm	Ø mm	A mm	
200	30	33	3 009100885

910M/55

cricchetto reversibile con attacco quadro maschio 3/8" con impugnatura in metallo

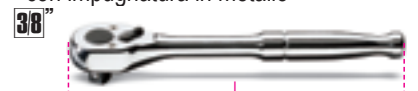

DIN 3122 - UNI ISO 3315

L mm	Ø mm	A mm	
178	30	26	2 009100875

910M/56

cricchetto reversibile snodato con attacco quadro maschio 3/8" con impugnatura in metallo



L mm	Ø mm	A mm	
265	31	29	2 009100887

910/58

cricchetto reversibile con impugnatura rotante con attacco quadro maschio 3/8" meccanismo a 52 denti

- Pulsante di rilascio della bussola
- Sistema di inversione a ghiera sulla testa del cricchetto
- Impugnatura bimateriale



L mm	Ø mm	A mm	
222	37	38,5	1 009100884

910.../C10

10 chiavi a bussola e 2 accessori







910A/C10 1 009100909

910A	6 - 7 - 8 - 10 - 11 - 12 13 - 14 - 17 - 19 mm
910/21	125 mm
910/55	

270x120x45 mm - 1,3 kg

Meccanismi rotanti di ricambio dei cricchetti, vedi tabella dopo l'art. 929/C8

910B/C10 1 009100910

-  ○ 910B 6 - 7 - 8 - 10 - 11 - 12
13 - 14 - 17 - 19 mm
-  910/21 125 mm
-  910/55
-  270x120x45 mm -  1,3 kg







910A/C16...

16 chiavi a bussola esagonali
e 5 accessori









38"



910A/C16 1 009100936

-  ○ 910A 6 - 7 - 8 - 9 - 10 - 11 - 12 - 13
14 - 15 - 16 - 17 - 18 - 19
21 - 22 mm
-  910/21 125 mm
-  910/22 250 mm
-  910/25
-  910/42
-  910/55
-  335x145x60 mm -  2,3 kg

910A/C16Q 1 009100932

-  ○ 910A 6 - 7 - 8 - 9 - 10 - 11 - 12 - 13
14 - 15 - 16 - 17 - 18 - 19
21 - 22 mm
-  910/21 125 mm
-  910/22 250 mm
-  910/25
-  910/42
-  910/55Q
-  335x145x60 mm -  2,3 kg









910B/C16...

16 chiavi a bussola poligonali
e 5 accessori









38"



910B/C16 1 009100937

-  ○ 910B 6 - 7 - 8 - 9 - 10 - 11 - 12 - 13
14 - 15 - 16 - 17 - 18 - 19
21 - 22 mm
-  910/21 125 mm
-  910/22 250 mm
-  910/25
-  910/42
-  910/55
-  335x145x60 mm -  2,3 kg

910B/C16Q 1 009100933

-  ○ 910B 6 - 7 - 8 - 9 - 10 - 11 - 12 - 13
14 - 15 - 16 - 17 - 18 - 19
21 - 22 mm
-  910/21 125 mm
-  910/22 250 mm
-  910/25
-  910/42
-  910/55Q
-  335x145x60 mm -  2,3 kg













910A/C17

17 chiavi a bussola esagonali
e 9 accessori

38"



910A/C17 1 009100938

-  ○ 910A 6 - 7 - 8 - 9 - 10 - 11 - 12 - 13
14 - 15 - 16 - 17 - 18 - 19 - 20
21 - 22 mm
-  910/15 □ 3/8 - ■ 1/4
-  910/16 □ 3/8 - ■ 1/2
-  910/21 125 mm
-  910/22 250 mm
-  910/25
-  910/36A
-  910/42
-  910/46
-  910/55
-  420x280x60 mm -  4,0 kg

910.../C29

17 chiavi a bussola
12 a giravite e 5 accessori











38"



910A/C29 1 009100944

-  ○ 910A 6 - 7 - 8 - 9 - 10 - 11 - 12 - 13
14 - 15 - 16 - 17 - 18 - 19 - 20
21 - 22 mm
-  910LP 1x5,5 - 1,2x6,5 - 1,2x8 mm
-  910PH PH1 - PH2 - PH3
-  910PE 3 - 4 - 5 - 6 - 8 - 10 mm
-  910/21 125 mm
-  910/22 250 mm
-  910/25
-  910/42
-  910/55
-  420x185x60 mm -  3,5 kg

910B/C29 1 009100945

-  ○ 910B 6 - 7 - 8 - 9 - 10 - 11 - 12 - 13
14 - 15 - 16 - 17 - 18 - 19 - 20
21 - 22 mm
-  910LP 1x5,5 - 1,2x6,5 - 1,2x8 mm
-  910PH PH1 - PH2 - PH3
-  910PE 3 - 4 - 5 - 6 - 8 - 10 mm
-  910/21 125 mm
-  910/22 250 mm
-  910/25
-  910/42
-  910/55
-  420x185x60 mm -  3,5 kg

910AS/C13...

13 chiavi a bussola poligonali
e 5 accessori

38"



910AS/C13 1 009100925

-  ○ 910AS 1/4 - 5/16 - 11/32 - 3/8 - 7/16
1/2 - 9/16 - 19/32 - 5/8 - 11/16
3/4 - 13/16 - 7/8
-  910/21 125 mm
-  910/22 250 mm
-  910/42
-  910/25
-  910/55
-  335x145x60 mm -  2,3 kg

910AS/MBM-C18

13 chiavi a bussola poligonali
e 5 accessori
per manutenzioni aeronautiche

38"



910AS/MBM-C18

1 009100926

	910AS	1/4 - 5/16 - 11/32 - 3/8 - 7/16 1/2 - 9/16 - 19/32 - 5/8 - 11/16 3/4 - 13/16 - 7/8
	910/21	125 mm
	910/22	250 mm
	910/25	
	910/42	
	910M/55	
335x145x60 mm - 2,5 kg		

910A/C16HR

16 chiavi a bussola
esagonali e 5 accessori

• cricchetto con impugnatura rotante

38"



910A/C16HR

1 009100935

	910A	6 - 7 - 8 - 9 - 10 - 11 - 12 - 13 14 - 15 - 16 - 17 - 18 - 19 21 - 22 mm
	910/21	125 mm
	910/22	250 mm
	910/25	
	910/42	
	910/58	
335x145x60 mm - 2,4 kg		

920A

chiavi a bussola a mano
bocca esagonale

12"



UNI/ISO 2725 DIN 3124

mm	Ø	L	Ø1		
8	12,4	38	21,7	10	009200008
9	13,5	38	21,7	10	009200009
10	14,9	38	21,7	10	009200010
11	16,1	38	21,7	10	009200011
12	17,5	38	21,7	10	009200012
13	18,7	38	21,7	10	009200013
14	20,1	38	21,7	10	009200014
15	21,5	38	22,5	10	009200015
16	22,7	38	23,7	10	009200016
17	24,1	38	23,1	10	009200017
18	25,3	39	24,0	10	009200018
19	26,6	39	24,0	10	009200019
20	27,8	40	25,0	5	009200020
21	28,8	40	25,0	5	009200021
22	29,9	41	26,0	5	009200022
23	30,8	42	26,0	5	009200023
24	32,2	43	27,0	5	009200024
25	33,2	44	27,0	5	009200025
26	34,7	45	28,0	5	009200026
27	36,2	46	29,0	5	009200027
28	37,2	47	30,0	5	009200028
29	38,6	48	31,0	5	009200029
30	40,2	48	32,0	5	009200030
32	42,3	49	34,0	5	009200032

12"



920A/SB13

10-11-12-13-14-15-16
17-18-19-20-21-22 mm

1 009200040

12"



920A/SB8

23-24-25-26-27-28-30-32 mm

1 009200042

920B

chiavi a bussola a mano
bocca poligonale

12"



UNI/ISO 2725 DIN 3124

mm	Ø	L	Ø1		
8	12,4	38	21,7	10	009200108
9	13,5	38	21,7	10	009200109
10	14,9	38	21,7	10	009200110
11	16,1	38	21,7	10	009200111
12	17,5	38	21,7	10	009200112
13	18,7	38	21,7	10	009200113
14	20,1	38	21,7	10	009200114
15	21,5	38	22,5	10	009200115
16	22,7	38	23,7	10	009200116
17	24,1	38	23,1	10	009200117

mm	Ø	L	Ø1		
18	25,3	39	24,0	10	009200118
19	26,6	39	24,0	10	009200119
20	27,8	40	25,0	5	009200120
21	28,8	40	25,0	5	009200121
22	29,9	41	26,0	5	009200122
23	30,8	42	26,0	5	009200123
24	32,2	43	27,0	5	009200124
25	33,2	44	27,0	5	009200125
26	34,7	45	28,0	5	009200126
27	36,2	46	29,0	5	009200127
28	37,2	47	30,0	5	009200128
29	38,6	48	31,0	5	009200129
30	40,2	48	32,0	5	009200130
32	42,3	49	33,9	5	009200132

12"



920B/SB13

10-11-12-13-14-15-16
17-18-19-20-21-22 mm

1 009200140

12"



920B/SB8

23-24-25-26-27
28-30-32 mm

1 009200142

920AL

chiavi a bussola a mano lunghe
bocca esagonale

12"



UNI/ISO 2725 DIN 3124

mm	Ø	L	Ø1		
10	14,7	77	21	5	009200626
12	17,8	77	21	5	009200627
13	19,0	77	22	5	009200628
14	20,3	77	22	5	009200629
15	21,5	77	22	5	009200630
16	22,8	77	22	5	009200631
17	24,0	77	23	5	009200632
18	25,0	77	24	5	009200633
19	26,5	77	25	5	009200634
21	29,0	77	27	5	009200635
22	30,0	77	28	5	009200636
23	31,5	77	29	5	009200637
24	32,8	77	30	5	009200638
27	36,5	77	33	3	009200639
30	40,0	77	36	3	009200640
32	42,8	77	38	3	009200641
36	48,0	77	41	3	009200642

12"



920AL/SB11

10-12-13-14-15-16
17-18-19-21-22 mm

1 009200644

Beta

Beta

920BL

chiavi a bussola a mano lunghe
bocca poligonale

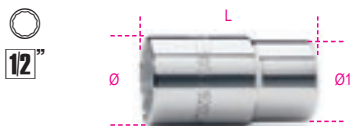

UNI/ISO 2725 DIN 3124

mm	Ø	L	Ø1		
mm	mm	mm	mm		
10	14,7	77	21	5	009200310
12	17,8	77	21	5	009200312
13	19,0	77	22	5	009200313
14	20,3	77	22	5	009200314
15	21,5	77	22	5	009200315
16	22,8	77	22	5	009200316
17	24,0	77	23	5	009200317
18	25,0	77	24	5	009200318
19	26,5	77	25	5	009200319
21	29,0	77	27	5	009200321
22	30,0	77	28	5	009200322
23	31,5	77	29	5	009200323
24	32,8	77	30	5	009200324
27	36,5	77	33	3	009200327
30	40,0	77	36	3	009200330
32	42,8	77	38	3	009200332
36	48,0	77	41	3	009200336



920BL/SB11
10-12-13-14-15-16-17-18
19-21-22 mm

1 009200338

920A/AS

chiavi a bussola a mano
bocca esagonale

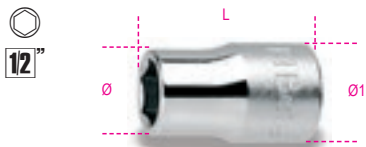

mm	Ø	L	Ø1		
mm	mm	mm	mm		
3/8	14,6	37	21	2	009200270
7/16	16,5	37	21	3	009200272
1/2	19,0	37	22	3	009200273
9/16	20,3	37	22	3	009200274
19/32	21,0	37	22	3	009200275
5/8	22,8	37	22	3	009200276
11/16	25,0	37	24	3	009200277
3/4	26,5	38	25	3	009200279
25/32	28,0	38	26	3	009200280
13/16	29,0	38	27	3	009200281
7/8	30,0	40	28	3	009200282
15/16	32,8	42	30	3	009200284
1	35,0	42	32	3	009200285
1.1/16	36,5	43	33	2	009200287
1.1/8	39,0	43	35	2	009200289
1.3/16	41,0	46	36	2	009200290
1.1/4	42,8	46	38	2	009200292



920A-AS/SB11
3/8-7/16-1/2-9/16-5/8
11/16-3/4-13/16-7/8
15/16-1

1 009200295

920AS

chiavi a bussola a mano
bocca poligonale

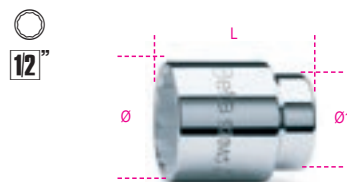

mm	Ø	L	Ø1		
mm	mm	mm	mm		
3/8	14,9	38	21,7	3	009200201
7/16	16,1	38	21,7	3	009200202
1/2	18,7	38	21,7	3	009200203
9/16	20,1	38	21,7	3	009200204
5/8	22,7	38	22,5	3	009200206
19/32	21,5	38	23,7	3	009200207
11/16	25,3	39	24,0	3	009200208
3/4	26,6	39	24,0	3	009200209
25/32	27,8	40	25,0	3	009200210
13/16	28,8	40	25,0	3	009200211
7/8	29,9	41	26,0	3	009200212
15/16	32,2	43	27,0	3	009200214
1	34,2	45	28,0	3	009200216
1.1/16	36,2	46	29,0	2	009200217
1.1/8	38,6	48	31,0	2	009200218
1.3/16	40,2	48	32,0	2	009200219
1.1/4	42,3	49	33,5	2	009200220



920AS/SB11
3/8-7/16-1/2-9/16-5/8
11/16-3/4-13/16-7/8
15/16-1

1 009200225

920AS/L

chiavi a bussola a mano lunghe
bocca poligonale



mm	Ø	L	Ø1		
mm	mm	mm	mm		
1/2	19,0	77	22	2	009200352
9/16	20,3	77	22	2	009200353
5/8	22,8	77	22	2	009200355
11/16	25,0	77	24	2	009200357
3/4	26,5	77	25	2	009200358
13/16	29,0	77	27	2	009200360
7/8	30,0	77	28	2	009200361
15/16	32,8	77	30	2	009200362
1	35,0	77	32	2	009200363
1.1/16	36,5	77	33,0	2	009200364
1.1/8	37,8	77	34	2	009200365



920ASL/SB11
1/2-9/16-5/8-11/16
3/4-13/16-7/8-15/16
1-1.1/8-1.1/16

1 009200369

920FTX

chiavi a bussola a mano per viti
con testa a profilo Torx®

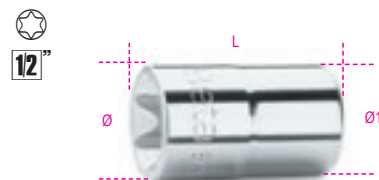

mm	Ø	L	Ø1		
mm	mm	mm	mm		
E10	13,2	36	21	5	009200380
E12	15,0	37	21	5	009200381
E14	16,3	37	21	5	009200382
E16	18,8	37	22	5	009200383
E18	20,4	37	22	5	009200384
E20	22,9	37	22	5	009200385
E22	25,0	37	24	3	009200387
E24	26,5	40	25	3	009200388



920FTX/SB6
E10-E12-E14
E16-E18-E20

1 009200390



920FTX/C8
E10-E12-E14-E16
E18-E20-E22-E24

1 009200391

270X120X45 mm - 1 kg

920FTX/L

chiavi a bussola a mano lunghe
per viti con testa a profilo Torx®



mm	Ø	L	Ø1		
mm	mm	mm	mm		
E10	13,2	77	21,0	5	009200400
E12	15,0	77	21,0	5	009200401
E14	16,3	77	21,0	5	009200402
E16	18,8	77	21,8	3	009200403
E18	20,4	77	21,8	3	009200404
E20	22,9	77	22,0	3	009200405



920FTX-LSB6
E10-E12-E14
E16-E18-E20

1 009200409

920LP

chiavi a bussola a giravite per viti con intaglio

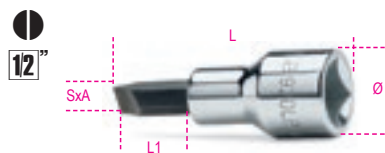

SxA	Ø	L	L1		
mm	mm	mm	mm		
1x5,5	22,5	62	24	3	009200452
1,2x6,5	22,5	62	24	3	009200453
1,2x8	22,5	62	24	3	009200454
1,6x9	22,5	62	24	3	009200456
2x12	22,5	62	24	3	009200458

920PH

chiavi a bussola a giravite per viti con impronta a croce Phillips®



PH	Ø	L	L1		
mm	mm	mm	mm		
1	22,5	56	18	3	009200471
2	22,5	56	18	3	009200472
3	22,5	56	18	3	009200473
4	22,5	56	18	3	009200474



920PH/SH4
PH1-PH2-PH3-PH4 1 009200479

920LH/SB7

chiavi a bussola a giravite per viti con impronta a croce Phillips®



920LH/SB7 1 009200478

920LP	1,2x6,5 - 1,2x8
920PH	PH2 - PH3 - PH4

920PE

chiavi a bussola maschio esagonale

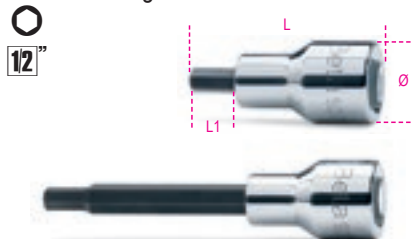

DIN 7422

mm	Ø	L	L1		
mm	mm	mm	mm		
3	22,5	58	20	5	009200410
4	22,5	58	20	5	009200412
5	22,5	58	20	5	009200414
5L	22,5	100	62	5	009200415
6	22,5	58	20	5	009200417
6L	22,5	100	62	5	009200418
7	22,5	58	20	5	009200420
7L	22,5	100	62	5	009200421
8	22,5	58	20	5	009200423
8L	22,5	100	62	5	009200424
9	22,5	58	20	5	009200425
9L	22,5	140	102	5	009200426
10	22,5	58	20	5	009200428
10L	22,5	140	102	5	009200429
12	23,0	58	20	5	009200432
12L	22,5	140	102	5	009200433
14	23,0	58	20	5	009200434
14L	22,5	140	102	5	009200435
17	29,5	60	22	5	009200437
19	29,5	60	22	5	009200439



920PE/SH9 1 009200441
4-5-6-8-10 mm
5L-6L-8L-10L mm



920PE/C10 1 009200443
4-5-6-7-8-10
12-14-17-19 mm
270X120X45 mm - 1,5 kg

920PE/AS

chiavi a bussola maschio esagonale



"	Ø	L	L1		
mm	mm	mm	mm		
1/8	22,5	58	20	2	009200460
3/16	22,5	58	20	2	009200461
1/4	22,5	58	20	2	009200463
3/8	22,5	58	20	2	009200464
1/2	22,5	60	20	2	009200465
3/4	22,5	60	20	1	009200468

12"



920PE-AS/SB6 1 009200469
1/8-3/16-1/4-3/8-1/2-3/4

920BP

chiavi a bussola maschio esagonale con estremità sferica

12"

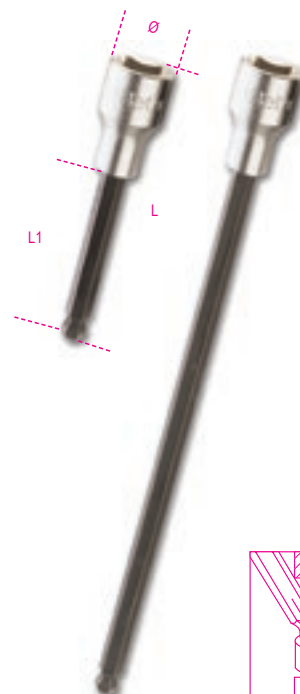

mm	Ø	L	L1		
mm	mm	mm	mm		
5L	22,5	100	62	5	009200490
5XL	22,5	240	202	1	009200495
6L	22,5	100	62	5	009200491
6XL	22,5	240	202	1	009200496
7L	22,5	100	62	5	009200492
8L	22,5	100	62	5	009200493
8XL	22,5	240	202	1	009200497
10L	22,5	140	102	5	009200494

12"



920BP/SB8 1 009200500
5L-6L-7L-8L-10L mm
5XL-6XL-8XL mm

920ME

chiavi a bussola
maschio esagonale



mm	Ø mm	L mm	L1 mm		
5	21	75	15,5	5	009200505
6	21	75	15,5	5	009200506
7	21	75	15,5	5	009200507
8	21	75	15,5	5	009200508
10	23	75	15,5	5	009200510
12	24	75	15,5	5	009200512
14	24	75	15,5	5	009200514
17	24	75	15,5	5	009200517



920ME/5B7
5-6-8-10-12-14-17 mm



920ME/C7
5-6-8-10-12-14-17 mm
250X100X35 mm - 1,4 kg

920TX

chiavi a bussola maschio
per viti con impronta Torx®



Ø mm	L mm	L1 mm		
T20	22,5	58	20	5 009200520
T20L	22,5	120	82	3 009200530
T25	22,5	58	20	5 009200521
T25L	22,5	120	82	3 009200531
T27	22,5	58	20	5 009200522
T27L	22,5	120	82	3 009200533
T30	22,5	58	20	5 009200523
T30L	22,5	120	82	3 009200534
T40	22,5	58	20	5 009200524
T40L	22,5	120	82	3 009200535
T45	22,5	58	20	5 009200525
T45L	22,5	120	82	3 009200537
T50	22,5	58	20	5 009200526
T50L	23,0	140	102	3 009200538
T55	23,0	58	20	3 009200527
T55L	23,0	140	102	3 009200539
T60	23,0	58	20	3 009200528
T60L	23,0	140	102	3 009200540
T70L	23,0	120	82	3 009200541



920TX/SB9
T20-T25-T27-T30
T40-T45-T50-T55-T60



920TX-L/SB10
T20L-T25L-T27L-T30L-T40L-
T45L-T50L-T55L-T60L-T70L



920TX/C9
T20-T25-T27-T30-T40
T45-T50-T55-T60

270X120X45 mm - 1,2 kg

920RTX

chiavi a bussola maschio per viti
con impronta Tamper Resistant Torx®

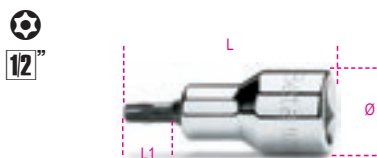

Ø mm	L mm	L1 mm		
T20	22,5	58	20	5 009200370
T25	22,5	58	20	5 009200371
T27	22,5	58	20	5 009200372
T30	22,5	58	20	5 009200373
T40	22,5	58	20	5 009200374



920RTX/SB5
T20-T25-T27-T30-T40

920XZN

chiavi a bussola maschio
a profilo XZN®

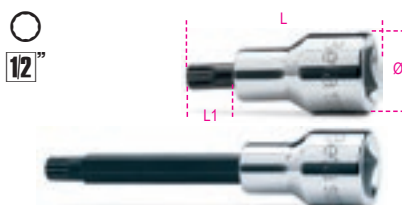

DIN 2324

Ø mm	L mm	L1 mm		
M4	22,5	58	20	3 009200559
M5	22,5	58	20	3 009200560
M6	22,5	58	20	3 009200561
M6L	22,5	100	62	3 009200562
M8	22,5	58	20	3 009200563
M8L	22,5	100	62	3 009200564
M9	22,5	58	20	3 009200582
M9L	22,5	100	62	3 009200583
M10	22,5	58	20	3 009200565
M10L	22,5	100	62	3 009200566
M12	22,5	58	20	3 009200568
M12L	22,5	100	62	3 009200569

Ø mm	L mm	L1 mm		
M14	23,0	58	20	3 009200571
M14L	23,0	100	62	3 009200572
M16	23,0	58	20	3 009200573
M18	23,0	58	20	3 009200574



920XZN/SB7
M4-M5-M6-M8
M10-M12-M14



920XZN/SB12
M5-M6-M8-M10-M12
M14-M16-M6L-M8L
M10L-M12L-M14L



920XZN-L/S5
M6L-M8L-M10L
M12L-M14L

920ES

chiavi a bussola per viti
con impronta esascalata



UNI 9326

Ø mm	L mm	L1 mm		
7	(6R)	58	20	5 009200587
7XL	(6R)	240	202	1 009200607
9	(8R)	58	20	5 009200589
9XL	(8R)	240	202	1 009200609
10	(8S)	58	20	5 009200590
10XL	(8S)	240	202	1 009200610
11	(10R)	58	20	5 009200591
11XL	(10R)	240	202	1 009200611
12L	(10S)	100	62	3 009200592
12XL	(10S)	240	202	1 009200612
14L	(12S)	100	62	3 009200594
14XL	(12S)	240	202	1 009200614
16L	(14R)	100	62	3 009200596
16XL	(14R)	240	202	1 009200616



920ES/SB7
7-9-10-11-12L-14L-16L



920ES-XL/SB7
7XL-9XL-10XL-11XL
12XL-14XL-16XL

920/15

raccordo con attacco quadro femmina 1/2" e maschio 3/8"



UNI/ISO 3316 DIN 3123

L	□	■	Ø		
mm	1/2	3/8	mm	5	009200810
42			22,0		



È assolutamente necessario commisurare la coppia di serraggio alla capacità del quadro maschio per evitare rotture o danni accidentali

920/16

raccordo con attacco quadro femmina 1/2" e maschio 3/4"



UNI/ISO 3316 DIN 3123

L	□	■	Ø		
mm	1/2	3/4	mm	5	009200814
46			26		

920/20÷920/23

prolunghe con attacchi quadri maschio e femmina 1/2"



UNI/ISO 3316 DIN 3123

	L	Ø		
	mm	mm		
920/20	75	22	5	009200818
920/21	125	22	5	009200822
920/22	255	22	5	009200826
920/23	375	22	2	009200827

920AN

prolunghe con attacchi quadri maschio e femmina 1/2" angolari

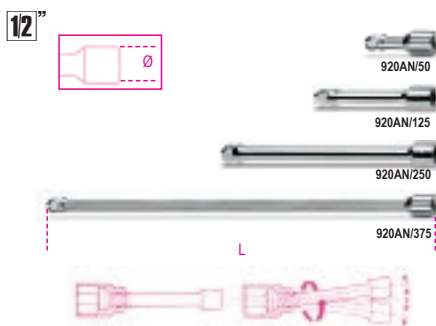

	L	Ø		
	mm	mm		
920AN/50	50	22	5	009200833
920AN/125	125	22	5	009200834
920AN/250	250	22	3	009200835
920AN/375	375	22	3	009200836

920/25

snodo con attacchi quadri maschio e femmina 1/2"



UNI/ISO 3316 DIN 3123

L	Ø		
mm	mm		
75	27	5	009200830

920/35A

quadro maschio 1/2" snodato con impugnatura

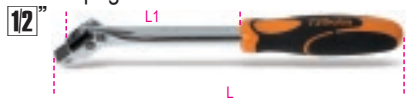

UNI/ISO 3315 DIN 3122

L	L1		
mm	mm		
285	160	3	009200846

920M/35

quadro maschio 1/2" snodato con impugnatura in metallo



UNI/ISO 3315 DIN 3122

L			
mm			
380	2	009200845	

920M/35L

quadro maschio 1/2" snodato con impugnatura in metallo, lungo



UNI/ISO 3315 DIN 3122

L			
mm			
600	1	009200843	



È assolutamente necessario applicare il carico di torsione adeguatamente e progressivamente per evitare rotture o danni accidentali.

920/36A

quadro maschio 1/2" snodato con impugnatura



UNI/ISO 3315 DIN 3122

L	L1		
mm	mm		
408	283	2	009200847

920/38

quadro maschio estensibile 1/2" snodato con impugnatura



L	L max		
mm	mm		
262	402	1	009200839

920/40

quadro maschio 1/2" snodato a T



L	L1		
mm	mm		
490	230	2	009200850

920/42

quadro maschio 1/2" con spina scorrevole

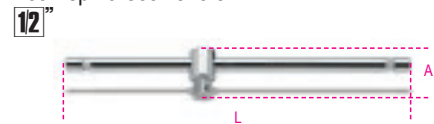

UNI/ISO 3315 DIN 3122

L	A		
mm	mm		
305	42	5	009200854

920/44

quadro maschio 1/2" ad angolo



UNI/ISO 3315 DIN 3122

L	L1		
mm	mm		
230	60	3	009200858

920/46

quadro maschio 1/2" con manovella

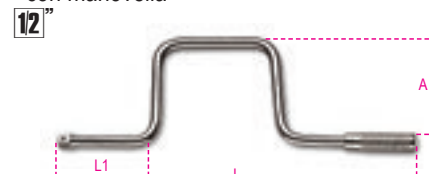

UNI/ISO 3315 DIN 3122

L	L1	A	
mm	mm	mm	
385	110	160	1
			009200862

920/50

cricchetto semplice
con attacco quadro scorrevole 1/2"
meccanismo a 72 denti



UNI/ISO 3315 DIN 3122

L	Ø	A	
mm	mm	mm	
275	40	42	3 009200871

920/50F

cricchetto semplice
con attacco quadro femmina 1/2"
meccanismo a 72 denti



UNI/ISO 3315 DIN 3122

L	Ø	A	
mm	mm	mm	
275	40	27	2 009200889

920/55

cricchetto reversibile
con attacco quadro maschio 1/2"
meccanismo a 72 denti



UNI/ISO 3315 DIN 3122

L	Ø	A	
mm	mm	mm	
275	40	43	3 009200882

920/55Q

cricchetto reversibile
con attacco quadro maschio 1/2"
meccanismo a 48 denti



UNI/ISO 3315 DIN 3122

L	Ø	A	
mm	mm	mm	
275	40	43	3 009200885

920/55X

cricchetto reversibile
con attacco quadro maschio 1/2"
meccanismo a 72 denti



UNI/ISO 3315 DIN 3122

L	Ø	A	
mm	mm	mm	
200	30	33	3 009200895

920/55LC

cricchetto reversibile
con attacco quadro maschio 1/2"
"Locking System"
meccanismo a 72 denti

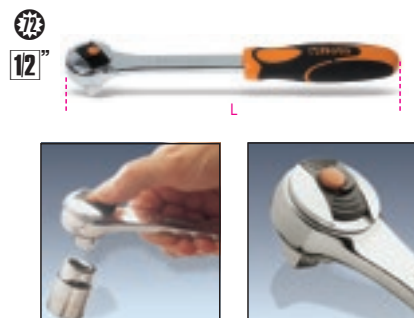

UNI/ISO 3315 DIN 3122

L	Ø	A	
mm	mm	mm	
275	40	43	2 009200896

920/55L

cricchetto estensibile reversibile
con attacco quadro maschio 1/2"
meccanismo a 72 denti



L	L max	Ø	A	
mm	mm	mm	mm	
282	422	40	43	1 009200927

920M/55

cricchetto reversibile
con attacco quadro maschio 1/2"
con impugnatura in metallo



L	Ø	A	
mm	mm	mm	
253	38	35	1 009200893

920/56A

cricchetto reversibile snodato
con attacco quadro maschio 1/2"
meccanismo a 72 denti



L	Ø	A	
mm	mm	mm	
315	40	43	1 009200911

920M/56

cricchetto reversibile snodato
con attacco quadro maschio 1/2"
con impugnatura in metallo

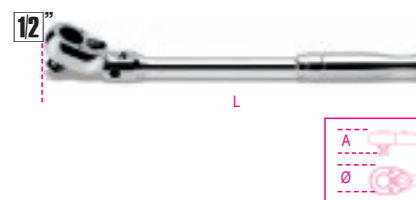

L	Ø	A	
mm	mm	mm	
330	38	35,7	2 009200894

920/58

cricchetto reversibile
con impugnatura rotante
con attacco quadro maschio 1/2"
meccanismo a 52 denti

- Pulsante di rilascio della bussola
- Sistema di inversione a ghiera sulla testa del cricchetto
- Impugnatura bimateriale



L	Ø	A	
mm	mm	mm	
281	42,5	45	1 009200926

**Meccanismi rotanti
di ricambio dei cricchetti,
vedi tabella dopo l'art. 929/C8**

920.../C11

11 chiavi a bussola
e 2 accessori

12"



920A/C11

1 009200921

- 920A 10 - 12 - 13 - 14 - 15 - 16
17 - 18 - 19 - 21 - 22 mm
 - 920/22 255 mm
 - 920/50
- 335x145x60 mm - 2,5 kg

920B/C11

1 009200922

- 920B 10 - 12 - 13 - 14 - 15 - 16
17 - 18 - 19 - 21 - 22 mm
 - 920/22 255 mm
 - 920/50
- 335x145x60 mm - 2,5 kg

920.../C12...

12 chiavi a bussola
e 5 accessori

12"



920A/C12X

1 009200933

- 920A 10 - 11 - 12 - 13 - 14 - 17 - 19
22 - 24 - 27 - 30 - 32 mm
 - 920/21 125 mm
 - 920/22 255 mm
 - 920/25
 - 920/42
 - 920/55
- 420x185x60 mm - 4,2 kg

920A/C12

1 009200931

- 920A 10 - 11 - 12 - 13 - 14 - 17 - 19
22 - 24 - 27 - 30 - 32 mm
 - 920/21 125 mm
 - 920/22 255 mm
 - 920/25
 - 920/42
 - 920/50
- 420x185x60 mm - 4,2 kg

920B/C12X

1 009200934

- 920B 10 - 11 - 12 - 13 - 14 - 17 - 19
22 - 24 - 27 - 30 - 32 mm
 - 920/21 125 mm
 - 920/22 255 mm
 - 920/25
 - 920/42
 - 920/55
- 420x185x60 mm - 4,0 kg

920B/C12

1 009200932

- 920B 10 - 11 - 12 - 13 - 14 - 17 - 19
22 - 24 - 27 - 30 - 32 mm
 - 920/21 125 mm
 - 920/22 255 mm
 - 920/25
 - 920/42
 - 920/50
- 420x185x60 mm - 4,0 kg

920.../C20...

20 chiavi a bussola
e 5 accessori

12"



920A/C20X

1 009200950

- 920A 10 - 11 - 12 - 13 - 14 - 15 - 16
17 - 18 - 19 - 20 - 21 - 22 - 23
24 - 26 - 27 - 28 - 30 - 32 mm
 - 920/21 125 mm
 - 920/22 255 mm
 - 920/25
 - 920/42
 - 920/55
- 420x185x60 mm - 5,1 kg

920A/C20

1 009200948

- 920A 10 - 11 - 12 - 13 - 14 - 15 - 16
17 - 18 - 19 - 20 - 21 - 22 - 23
24 - 26 - 27 - 28 - 30 - 32 mm
 - 920/21 125 mm
 - 920/22 255 mm
 - 920/25
 - 920/42
 - 920/50
- 420x185x60 mm - 5,1 kg

920A/C20Q

1 009200955

- 920A 10 - 11 - 12 - 13 - 14 - 15 - 16
17 - 18 - 19 - 20 - 21 - 22 - 23
24 - 26 - 27 - 28 - 30 - 32 mm
 - 920/21 125 mm
 - 920/22 255 mm
 - 920/25
 - 920/42
 - 920/55Q
- 420x185x60 mm - 5,1 kg

920B/C20

1 009200949

- 920B 10 - 11 - 12 - 13 - 14 - 15 - 16
17 - 18 - 19 - 20 - 21 - 22 - 23
24 - 26 - 27 - 28 - 30 - 32 mm
 - 920/21 125 mm
 - 920/22 255 mm
 - 920/25
 - 920/42
 - 920/50
- 420x185x60 mm - 5,0 kg

920B/C20X

1 009200951

- 920B 10 - 11 - 12 - 13 - 14 - 15 - 16
17 - 18 - 19 - 20 - 21 - 22 - 23
24 - 26 - 27 - 28 - 30 - 32 mm
 - 920/21 125 mm
 - 920/22 255 mm
 - 920/25
 - 920/42
 - 920/55
- 420x185x60 mm - 5,0 kg

920.../C21...

21 chiavi a bussola
e 6 accessori

12"









920A/C21

1 009200952

- 920A 10 - 11 - 12 - 13 - 14 - 15 - 16
17 - 18 - 19 - 20 - 21 - 22 - 23
24 - 25 - 26 - 27 - 28 - 30 - 32 mm
 - 920/21 125 mm
 - 920/22 255 mm
 - 920/25
 - 920/42
 - 920/46
 - 920/50
- 420x280x60 mm - 6,5 kg

920A/C21X







1 009200983

	○ 920A	10 - 11 - 12 - 13 - 14 - 15 - 16 17 - 18 - 19 - 20 - 21 - 22 - 23 24 - 25 - 26 - 27 - 28 - 30 - 32 mm
	920/21	125 mm
	920/22	255 mm
	920/25	
	920/42	
	920/46	
	920/55	

420x280x60 mm - 6,4 kg

920B/C21







1 009200953

	○ 920B	10 - 11 - 12 - 13 - 14 - 15 - 16 17 - 18 - 19 - 20 - 21 - 22 - 23 24 - 25 - 26 - 27 - 28 - 30 - 32 mm
	920/21	125 mm
	920/22	255 mm
	920/25	
	920/42	
	920/46	
	920/50	

420x280x60 mm - 6,4 kg

920B/C21X

1 009200984

	○ 920B	10 - 11 - 12 - 13 - 14 - 15 - 16 17 - 18 - 19 - 20 - 21 - 22 - 23 24 - 25 - 26 - 27 - 28 - 30 - 32 mm
	920/21	125 mm
	920/22	255 mm
	920/25	
	920/42	
	920/46	
	920/55	

420x280x60 mm - 6,4 kg

920B/C30Q30 chiavi a bussola poligonali
e 5 accessori

12"

**920B/C30Q**

1 009200975

	○ 920B	8 - 9 - 10 - 11 - 12 - 13 - 14 15 - 16 - 17 - 18 - 19 - 20 - 21 22 - 23 - 24 - 26 - 27 - 30 mm
	○ 920BL	12 - 13 - 14 - 17 - 19 - 21 22 - 24 - 27 - 30 mm
	920/21	125 mm
	920/22	255 mm
	920/25	
	920/42	
	920/55Q	









420x280x60 mm - 7,6 kg

920.../C3320 chiavi a bussola
13 a giravite e 5 accessori

12"

**920A/C33**

1 009200985

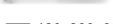
	○ 920A	10 - 11 - 12 - 13 - 14 - 15 - 16 17 - 18 - 19 - 20 - 21 - 22 - 23 24 - 26 - 27 - 28 - 30 - 32 mm
	● 920LP	1,2x8 - 1,6x9 - 2x12 mm
	⊕ 920PH	PH2 - PH3 - PH4
	○ 920PE	4 - 5 - 6 - 8 - 10 - 12 - 14 mm
	920/21	125 mm
	920/22	255 mm
	920/25	
	920/42	
	920/55	

420x280x60 mm - 6,7 kg

920B/C33

1 009200986

	○ 920B	10 - 11 - 12 - 13 - 14 - 15 - 16 17 - 18 - 19 - 20 - 21 - 22 - 23 24 - 26 - 27 - 28 - 30 - 32 mm
	● 920LP	1,2x8 - 1,6x9 - 2x12 mm
	⊕ 920PH	PH2 - PH3 - PH4
	○ 920PE	4 - 5 - 6 - 8 - 10 - 12 - 14 mm
	920/21	125 mm
	920/22	255 mm
	920/25	
	920/42	
	920/55	

420x280x60 mm - 6,7 kg

920/C3737 chiavi a bussola poligonali
e 5 accessori

12"

**920/C37**

1 009200988

	○ 920B	10 - 11 - 12 - 13 - 14 - 15 - 16 17 - 18 - 19 - 20 - 21 - 22 - 23 24 - 26 - 27 - 28 - 30 - 32 mm
	○ 920AS	3/8 - 7/16 - 1/2 - 9/16 - 19/32 5/8 - 11/16 - 3/4 - 25/32 - 13/16 7/8 - 15/16 - 1 - 1.1/16 - 1.1/8 1.3/16 - 1.1/4
	920/21	125 mm
	920/22	255 mm
	920/25	
	920/42	
	920/55	

420x280x60 mm - 7,5 kg



920AS/C10

10 chiavi a bussola poligonali
e 2 accessori

12"



920AS/C10 1 009200919

	○ 920AS	3/8 - 7/16 - 1/2 - 9/16 - 5/8 11/16 - 3/4 - 13/16 - 7/8 - 15/16
	920/22	255 mm
	920/50	
335x145x60 mm - 2,6 kg		

920AS/C15

15 chiavi a bussola poligonali
e 6 accessori

12"



920AS/C15 1 009200947

	○ 920AS	3/8 - 7/16 - 1/2 - 9/16 - 5/8 - 11/16 3/4 - 13/16 - 7/8 - 15/16 - 1 1.1/16 - 1.1/8 - 1.3/16 - 1.1/4
	920/21	125 mm
	920/22	255 mm
	920/25	
	920/42	
	920/46	
	920/50	
420x280x60 mm - 5,9 kg		

920AS/C17X

17 chiavi a bussola poligonali
e 5 accessori

12"



920AS/C17X 1 009200942

	○ 920AS	3/8 - 7/16 - 1/2 - 9/16 - 19/32 - 5/8 11/16 - 3/4 - 25/32 - 13/16 - 7/8 15/16 - 1 - 1.1/16 - 1.1/8 - 1.3/16 - 1.1/4
	920/21	125 mm
	920/22	255 mm
	920/25	
	920/42	
	920/55	
420x185x60 mm - 4,8 kg		

920AS/MBM-C21

16 chiavi a bussola poligonali
e 5 accessori
per manutenzioni aeronautiche

12"



920AS/MBM-C21 1 009200944

	○ 920AS	3/8 - 7/16 - 1/2 - 9/16 19/32 - 5/8 - 11/16 - 3/4 25/32 - 13/16 - 7/8 - 15/16 1 - 1.1/16 - 1.3/16 - 1.1/4
	920M/55	
	920/21	125 mm
	920/22	255 mm
	920/25	
	920/42	
420x185x60 mm - 5,0 kg		

920TX/C17

6 inserti per avvitatori
6 chiavi a bussola
5 chiavi a bussola maschio
e 4 accessori, per viti con impronta Torx®

12"



920TX/C17 1 009200989

	861TX	T8 - T10 - T15 - T20 - T25 - T27
	897	
	920TX	T27 - T30 - T40 - T45 - T50
	920FTX	E10 - E12 - E14 - E16 - E18 - E20
	920/20	75 mm
	920/22	255 mm
	920/55	
420x185x60 mm - 2,9 kg		

920A/C17HR

17 chiavi a bussola esagonali
in termoformato rigido, in cassetta di lamiera

• cricchetto con impugnatura rotante

12"



920A/C17HR 1 009200939

	○ 920A	10-11-12-13-14-15-16-17-18-19-20- 21-22-24-27-30-32 mm
	920/21	125 mm
	920/22	255 mm
	920/25	
	920/42	
	920/58	
420x185x60 mm - 5,1 kg		

928A

chiavi a bussola a mano
bocca esagonale



UNI/ISO 2725
DIN 3124

Ø mm	Ø mm	L mm	Ø1 mm		
19	29,2	50	34	5	009280019
21	30,0	51	34	5	009280021
22	31,3	53	34	5	009280022
23	33,3	53	34	5	009280023
24	34,5	53	34	5	009280024
26	36,8	55	35	5	009280026
27	38,0	56	35	5	009280027
28	39,0	57	35	3	009280028
29	40,2	58	35	3	009280029
30	41,5	58	37	3	009280030
32	44,3	60	37	3	009280032
33	45,8	60	37	3	009280033
34	46,8	60	37	3	009280034
35	48,1	62	38	3	009280035
36	49,5	64	38	3	009280036
38	52,0	68	40	3	009280038
41	56,0	71	40	3	009280041
46	62,3	75	43	3	009280046
50	67,4	80	43	3	009280050
55	73,7	84	48	1	009280055
60	80,0	87	48	1	009280060

928B

chiavi a bussola a mano
bocca poligonale



UNI/ISO 2725
DIN 3124

Ø mm	Ø mm	L mm	Ø1 mm		
19	29,2	50	34	5	009280119
21	30,0	51	34	5	009280121
22	31,3	53	34	5	009280122
23	33,3	53	34	5	009280123
24	34,5	53	34	5	009280124
26	36,8	55	35	5	009280126
27	38,0	56	35	5	009280127
28	39,0	57	35	3	009280128
29	40,2	58	35	3	009280129
30	41,5	58	37	3	009280130
32	44,3	60	37	3	009280132
33	45,8	60	37	3	009280133
34	46,8	60	37	3	009280134
35	48,1	62	38	3	009280135
36	49,5	64	38	3	009280136
38	52,0	68	40	3	009280138
41	56,0	71	40	3	009280141
46	62,3	75	43	3	009280146
50	67,4	80	43	3	009280150
55	73,7	84	48	1	009280155
60	80,0	87	48	1	009280160

928AS

chiavi a bussola a mano
bocca esagonale



Ø mm	Ø mm	L mm	Ø1 mm		
7/8	32,0	53	34	1	009280202
15/16	34,5	53	34	1	009280203
1	36,2	55	35	1	009280204
1.1/16	38,0	56	35	1	009280205
1.1/8	40,2	58	35	1	009280206
1.1/4	44,2	60	37	1	009280208
1.5/16	45,8	60	37	1	009280209
1.3/8	48,1	62	38	1	009280210
1.7/16	49,5	64	38	1	009280211
1.1/2	52,0	68	40	1	009280212
1.5/8	56,0	71	40	1	009280214
1.11/16	58,8	74	40	1	009280215
1.13/16	62,3	75	43	1	009280217
1.7/8	65,0	78	43	1	009280218
2	68,3	80	43	1	009280219
2.1/16	71,5	83	48	1	009280220

928ME

chiavi a bussola
maschio esagonale



mm	Ø mm	L mm	L1 mm		
14	35	75	15,5	2	009280514
17	35	75	15,5	2	009280517
19	35	75	15,5	2	009280519
22	35	75	22,5	2	009280522

928/15

raccordo con attacco quadro
femmina 3/4" e maschio 1/2"



UNI/ISO 3316
DIN 3123

L mm	Ø mm	□	■		
51,5	34	3/4	1/2	5	009280801



E' assolutamente necessario commisurare la coppia di serraggio alla capacità del quadro maschio per evitare rotture o danni accidentali

928/16

raccordo con attacco quadro
femmina 3/4" e maschio 1"



UNI/ISO 3316
DIN 3123

L mm	Ø mm	□	■		
65	34	3/4	1"	5	009280807

928/20 - 928/21 - 928/22

prolunghe con attacchi quadri
maschio e femmina 3/4"

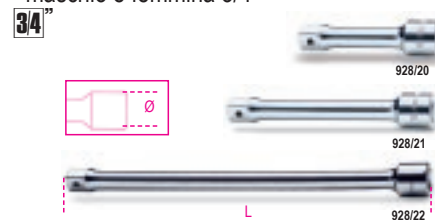

UNI/ISO 3316
DIN 3123

	L mm	Ø mm		
928/20	100	34	3	009280810
928/21	200	34	3	009280815
928/22	380	34	3	009280825

928/25

snodo con attacchi quadri maschio
e femmina 3/4"



UNI/ISO 3316 DIN 3123

L mm	Ø mm		
108	40	1	009280830

928/36A

quadro maschio 3/4" snodato
con impugnatura



UNI/ISO 3315
DIN 3122

L mm			
545	1	009280844	

928/42

quadro maschio 3/4"
con spina scorrevole

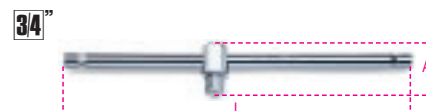

UNI/ISO 3315 DIN 3122

L mm	A mm		
450	62,5	3	009280850

928/55

cricchetto reversibile
con attacco quadro maschio 3/4"
meccanismo a 72 denti



UNI/ISO 3315 DIN 3122

L mm	Ø mm	A mm	
510	58	59	2 009280862

**Meccanismi rotanti
di ricambio dei cricchetti,
vedi tabella dopo l'art. 929/C8**

928.../C12

12 chiavi a bussola esagonali e 5 accessori in
cassetta di lamiera



928A/C12

928A 22 - 24 - 27 - 30 - 32 - 34 - 36
38 - 41 - 46 - 50 - 55 mm

928/21	200 mm
928/22	380 mm
928/25	
928/42	
928/55	

530x220x80 mm - 13,5 kg

928B/C12

928B 22 - 24 - 27 - 30 - 32 - 34 - 36
38 - 41 - 46 - 50 - 55 mm

928/21	200 mm
928/22	380 mm
928/25	
928/42	
928/55	

530x220x80 mm - 13,5 kg

928AS/C12

12 chiavi a bussola esagonali e 5 accessori in
cassetta di lamiera



928AS/C12

928AS 7/8-15/16-1.1/16-1.1/8-1.1/4
1.5/16-1.7/16-1.1/2-1.11/16
1.13/16-1.7/8-2.1/16

928/21	200 mm
928/22	380 mm
928/25	
928/42	
928/55	

530x220x80 mm - 13,5 kg

929

chiavi a bussola a mano
bocca esagonale



UNI/ISO 2725 DIN 3124

Ø mm	L mm	Ø1 mm	
36	51	65	48
41	57	70	48
46	65	75	48
50	70	80	48
55	76	85	54
60	82	90	54
65	88	95	54
70	92	100	60
75	99	110	60
80	106	120	60

929/15

raccordo con attacco quadro
femmina 1" e maschio 3/4"

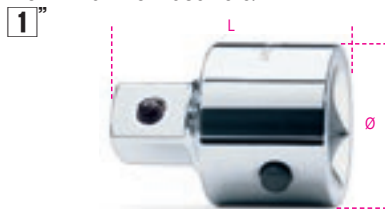

UNI/ISO 3316 DIN 3123

L mm	Ø mm	1"	3/4"	
65	47			2 009290801



E' assolutamente necessario commisurare la
coppia di serraggio alla capacità del quadro
maschio per evitare rotture o danni accidentali

929/21 - 929/22

prolunghe con attacchi quadri
maschio e femmina 1"



UNI/ISO 3316 DIN 3123

	L mm	Ø mm	
929/21	200	47	1 009290815
929/22	400	47	1 009290825

929/42

quadro maschio 1"
con spina scorrevole



UNI/ISO 3315 DIN 3122

L mm		
535		1 009290850

929/55

cricchetto reversibile
con attacco quadro maschio 1"
meccanismo a 72 denti



UNI/ISO 3315 DIN 3122

L mm	Ø mm	A mm	
770	62	63	1 009290860

929/C8

8 chiavi a bussola esagonali
e 5 accessori



929/C8

929 46 - 50 - 55 - 60 - 65
70 - 75 - 80 mm

929/15	□ 1" - ■ 3/4"
929/21	200 mm
929/22	400 mm
929/42	
929/55	

560x290x12 mm - 29 kg

900/R55

14"
40



900/R55
900/55 1 009000871

900M/R55

14"



900M/R55
900M/55 1 009000888

910/R55

38"
72



910/R55
606/6-606/10-612
666/6-666/10-910/55
599DGT/6 1 009100879

910M/R55

38"



910M/R55
910M/55-910M/56 1 009100888

910/R55Q

38"
40



910/R55Q
910/55Q 1 009100877

910/R55X

38"
40



910/R55X
666N/2X 1 009100897

920/R50

12"
72



920/R50
614/50-667/20-667/30
920/50 1 009200866

920/R55

12"
72



920/R55
606/20-606/30-666/20-666/30
920/55-920/56A- 599DGT/20-599DGT/30 1 009200879

920M/R55

12"



920M/R55
920M/55-920M/56 1 009200888

920/R55Q

12"
40



920/R55Q
920/55Q 1 009200877

920/R55X

12"
72



920/R55X
606/10X-612X
666/10X-920/55X-599DGT/10X 1 009200878

920/R55LC

12"
72



920/R55LC
920/55LC "Locking System" 1 009200887

928/R55

34"
72



928/R55
928/55 1 009280859

928/R55X

34"
72



928/R55X
614X 1 009280858

929/R55

1"
72



929/R55
929/55 1 009290859

930

chiavi a tubo doppie poligonali
serie pesante



UNI 6745

Ø	L	Ø	Ø1	
mm	mm	mm	mm	
6x7	100	9,5	11,0	3 009300006
8x9	108	12,5	14,0	3 009300010
10x11	116	15,0	16,5	3 009300014
12x13	124	17,5	19,0	3 009300018
14x15	132	20,0	21,5	3 009300023
16x17	140	23,0	24,0	3 009300027
18x19	148	25,0	26,5	3 009300032
20x22	156	28,0	30,0	2 009300036
21x23	163	29,0	31,5	2 009300040
24x26	173	33,0	35,5	2 009300044
25x28	182	34,5	38,0	2 009300048
27x29	191	37,0	39,5	2 009300052
30x32	200	40,5	43,0	2 009300056



930/S8 1 009300081

6x7-8x9-10x11
12x13-14x15-16x17
18x19-20x22 mm

940/1 - /2

930/S13 1 009300083

6x7-8x9-10x11-12x13
14x15-16x17-18x19

20x22-21x23-24x26

25x28-27x29-30x32 mm

940/1 - /2 - /3



930/C13
 6x7-8x9-10x11-12x13
 14x15-16x17-18x19
 20x22-21x23-24x26
 25x28-27x29-30x32 mm
940/1 - /2 - /3

932
 chiavi a pipa doppie
 esagonali-poligonali
 cromate lucide

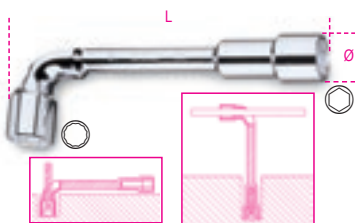

NF E 74.303

mm	Ø	L	
6x6	11,5	110	5 009320006
7x7	12,5	116	5 009320007
8x8	13,0	120	5 009320008
9x9	14,0	125	5 009320009
10x10	16,5	133	5 009320010
11x11	17,5	143	5 009320011
12x12	19,0	148	5 009320012
13x13	19,5	154	5 009320013
14x14	21,5	167	5 009320014
15x15	22,5	182	5 009320015
16x16	24,5	193	5 009320016
17x17	26,0	198	5 009320017
18x18	26,5	215	5 009320018
19x19	29,0	220	5 009320019
20x20	30,5	222	3 009320020
21x21	30,5	236	3 009320021
22x22	32,5	250	2 009320022
23x23	33,5	256	2 009320023
24x24	35,0	272	2 009320024
25x25	36,5	282	2 009320025
26x26	37,5	296	2 009320026
27x27	39,0	296	2 009320027
28x28	39,0	314	2 009320028
30x30	42,5	348	2 009320030
32x32	45,5	364	2 009320032



932/S11 6-7-8-10-11-12 13-14-17-19-22 mm	1 009320080
932/S17 6-7-8-9-10-11-12 13-14-15-16-17 18-19-20-21-22 mm	1 009320081
932/S25 6-7-8-9-10-11-12-13 14-15-16-17-18-19 20-21-22-23-24-25 26-27-28-30-32 mm	1 009320082

933
 chiavi a pipa doppie
 esagonali
 cromate lucide

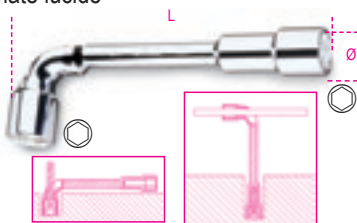

NF E 74.303

mm	Ø	L	
6x6	11,5	110	5 009330006
7x7	12,5	116	5 009330007
8x8	13,0	120	5 009330008
9x9	14,0	125	5 009330009
10x10	16,5	133	5 009330010
11x11	17,5	143	5 009330011
12x12	19,0	148	5 009330012
13x13	19,5	154	5 009330013
14x14	21,5	167	5 009330014
15x15	22,5	182	5 009330015
16x16	24,5	193	5 009330016
17x17	26,0	198	5 009330017
18x18	26,5	215	5 009330018
19x19	29,0	220	5 009330019
20x20	30,5	222	3 009330020
21x21	30,5	236	3 009330021
22x22	32,5	250	2 009330022
23x23	33,5	256	2 009330023
24x24	35,0	272	2 009330024
25x25	36,5	282	2 009330025
26x26	37,5	296	2 009330026
27x27	39,0	296	2 009330027
28x28	39,0	314	2 009330028
30x30	42,5	348	2 009330030
32x32	45,5	364	2 009330032

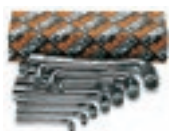

933/S11 6-7-8-10-11-12 13-14-17-19-22 mm	1 009330080
933/S17 6-7-8-9-10-11-12 13-14-15-16-17 18-19-20-21-22 mm	1 009330081
933/S25 6-7-8-9-10-11-12-13 14-15-16-17-18-19 20-21-22-23-24-25 26-27-28-30-32 mm	1 009330082

935
 chiavi a tubo doppie
 esagonali
 serie leggera



UNI 6746 DIN 896

mm	L	
6x7	100	5 009350105
8x9	110	5 009350111
10x11	120	5 009350115
12x13	130	5 009350117
14x15	140	5 009350126
16x17	150	5 009350128
18x19	160	5 009350131
20x22	170	3 009350138
21x23	180	3 009350141
24x26	190	3 009350144
25x28	200	2 009350150
27x29	210	2 009350153
30x32	220	2 009350156

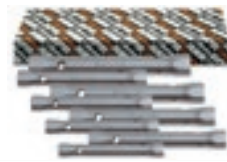

935/S8
 6x7-8x9-10x11
 12x13-14x15-16x17
 18x19-20x22 mm

940/1 - /2
935/S13
 6x7-8x9-10x11
 12x13-14x15-16x17
 18x19-20x22-21x23
 24x26-25x28-27x29
 30x32 mm
940/1 - /2 - /3

937
 chiavi a pipa doppie
 esagonali-poligonali
 cromate

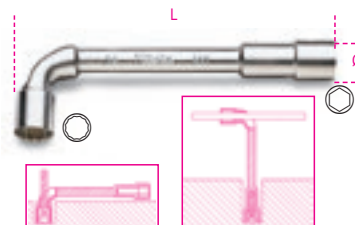

mm	Ø	L	
6x6	11,5	110	5 009370006
7x7	12,5	116	5 009370007
8x8	13,0	120	5 009370008
9x9	14,0	125	5 009370009
10x10	16,5	133	5 009370010
11x11	17,5	143	5 009370011
12x12	19,0	148	5 009370012
13x13	19,5	154	5 009370013
14x14	21,5	167	5 009370014
15x15	22,5	182	5 009370015
16x16	24,5	193	5 009370016
17x17	26,0	198	5 009370017
18x18	26,5	215	5 009370018
19x19	29,0	220	5 009370019
20x20	30,5	222	3 009370020
21x21	30,5	236	3 009370021
22x22	32,5	250	2 009370022
23x23	33,5	256	2 009370023
24x24	35,0	272	2 009370024
25x25	36,5	282	2 009370025
26x26	37,5	296	2 009370026
27x27	39,0	296	2 009370027
28x28	39,0	314	2 009370028
30x30	42,5	348	2 009370030
32x32	45,5	364	2 009370032



937/S11 6-7-8-10-11-12 13-14-17-19-22 mm	1 009370080
937/S17 6-7-8-9-10-11-12 13-14-15-16-17 18-19-20-21-22 mm	1 009370081

940

spine di manovra per 930-935



	mm	L		
	6÷13	mm		
940/1		100	5	009400001
940/2	14÷22	170	5	009400002
940/3	21÷32	290	5	009400003

941

chiavi a pipa esagonali-poligonali con impugnatura di manovra



mm	L	L1	A1		
mm	mm	mm	mm		
7x7	200	91	35	2	009410107
8x8	220	107	50	2	009410108
9x9	220	109	50	2	009410109
10x10	236	111	50	2	009410110
11x11	236	114	50	2	009410111
12x12	255	122	50	2	009410112
13x13	255	124	55	2	009410113



941/S7
7-8-9-10-11-12-13 mm 1 009410170

942BX

chiavi a bussola esagonale tipo corto



UNI 6750

mm	L	L1	A1		
mm	mm	mm	mm		
4	190	70	13,0	5	009420003
5	190	70	14,0	5	009420004
5,5	190	70	12,5	5	009420005
6	190	70	14,5	5	009420006
7	190	70	15,5	5	009420007
8	202	70	18,5	5	009420008
9	202	70	19,5	5	009420009
10	202	70	20,5	3	009420010
11	202	70	21,5	3	009420011
12	202	70	22,5	3	009420012
13	202	70	23,5	3	009420013
14	202	70	24,5	3	009420014



942BX/S12
4-5-5,5-6-7-8-9
10-11-12-13-14 mm 1 009420030

943BX

chiavi a bussola esagonale tipo lungo



ISO 2236 UNI 6750

mm	L	L1	A1		
mm	mm	mm	mm		
4	270	150	13,0	5	009430003
5	270	150	14,0	5	009430004
5,5	270	150	12,5	5	009430005
6	270	150	14,5	5	009430006
7	270	150	15,5	5	009430007
8	282	150	18,5	5	009430008
9	282	150	19,5	5	009430009
10	282	150	20,5	3	009430010
11	282	150	21,5	3	009430011
12	282	150	22,5	3	009430012
13	282	150	23,5	3	009430013
14	282	150	24,5	3	009430014



943BX/S12
4-5-5,5-6-7-8-9
10-11-12-13-14 mm 1 009430030



943BX/D6
5-6-7-8-10-13 mm 1 009430026



943FL

chiavi a bussola esagonale flessibili con impugnatura



mm	L	L1	Ø		
mm	mm	mm	mm		
5	265	150	8	2	009430304
5,5	265	150	8	2	009430305
6	265	150	9	2	009430306
7	265	150	11	2	009430307
8	265	150	12	2	009430308
10	290	175	14	2	009430310



943FL/S6
5-5,5-6-7-8-10 mm 1 009430320

944BX

chiavi a bussola esagonale profonda tipo lungo



ISO 2236 UNI 6750

mm	L	L1	A1		
mm	mm	mm	mm		
4	245	125	20	3	009440003
5	245	125	25	3	009440004
5,5	245	125	30	3	009440005
6	245	125	35	3	009440006
7	245	125	35	3	009440007
8	257	125	50	3	009440008
9	257	125	50	3	009440009
10	257	125	50	3	009440010
11	257	125	50	3	009440011
12	257	125	50	3	009440012
13	257	125	55	3	009440013
14	257	125	55	3	009440014



944BX/S12
4-5-5,5-6-7-8-9
10-11-12-13-14 mm 1 009440062

Betamax



944BX/D6
5-6-7-8-10-13 mm

1 009440056

949

chiavi a T semplici
con bussola esagonale profonda

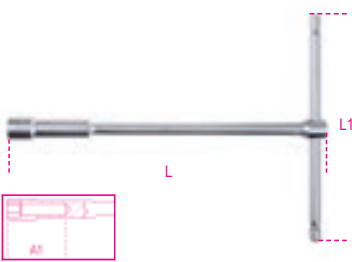

mm	L mm	L1 mm	A1 mm	
8	220	160	50	2 009490008
10	230	160	50	2 009490010
12	240	175	50	2 009490012
13	244	175	55	2 009490013
14	250	190	55	2 009490014
17	264	200	60	2 009490017



949/S6
8-10-12-13-14-17mm

1 009490076

950

chiavi a T semplici
esagonali

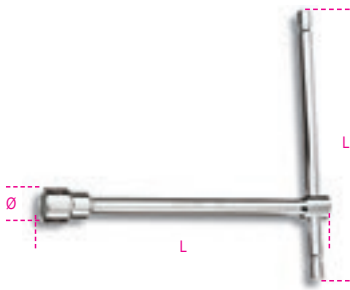

UNI 6742 DIN 3112

mm	L mm	Ø mm	L1 mm	
6	210	10,1	145	3 009500006
7	212	11,2	145	3 009500007
8	220	12,4	160	3 009500008
9	223	13,5	160	3 009500009
10	230	14,9	160	3 009500010
11	233	16,1	160	3 009500011
12	240	17,5	175	3 009500012
13	244	19,7	175	3 009500013
14	250	20,1	190	3 009500014
15	254	21,5	190	3 009500015
16	260	22,7	200	3 009500016
17	264	24,1	200	3 009500017
19	274	26,6	230	3 009500019
22	290	29,9	290	2 009500022
24	300	32,2	320	2 009500024
27	315	36,2	370	2 009500027



950/S9
7-8-10-11-12
13-14-17-19 mm

1 009500079

950/S14
6-7-8-9-10-11-12-13
14-15-16-17-19-22 mm

1 009500082

951

chiavi a T con tre estremità
maschio esagonale

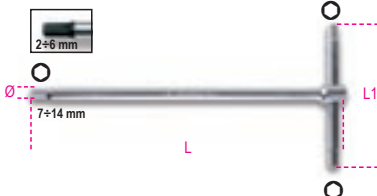

mm	L mm	L1 mm	Ø mm	
2	125	63	4,0	5 009510521
2,5	150	63	4,0	5 009510525
3	150	63	4,0	5 009510530
3,5	175	76	5,5	5 009510535
4	175	76	5,5	5 009510540
4,5	195	87	6,5	5 009510545
5	195	87	6,5	5 009510550
6	215	99	8,0	5 009510560
7	230	109	9,0	5 009510570
8	250	122	10,0	5 009510580
9	265	132	11,0	5 009510590
10	280	142	12,0	5 009510610
12	305	160	15,0	3 009510620
14	330	178	17,0	3 009510640

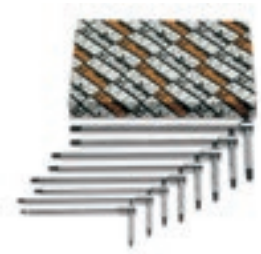

951/S6
2,5-3-4-5-6-8 mm

1 009510687

951/S8
2-2,5-3-3,5-4-4,5-5-6 mm

1 009510693

951/S14
2-2,5-3-3,5-4-4,5
5-6-7-8-9-10-12-14 mm

1 009510695



951/SP6
3-4-5-6-8-10 mm

1 009510696

951/SPV

1 009510697

951AS

chiavi a T con tre estremità
maschio esagonale



"	L mm	L1 mm	Ø mm	
3/32	125	63	4,0	2 009510750
7/64	150	63	4,0	2 009510751
1/8	150	63	4,0	2 009510752
9/64	175	76	5,5	2 009510753
5/32	175	76	5,5	2 009510754
3/16	195	86	6,5	2 009510755
7/32	215	99	8,0	2 009510757
1/4	230	109	9,0	2 009510758
5/16	250	122	10,0	2 009510759
3/8	280	142	12,0	2 009510760

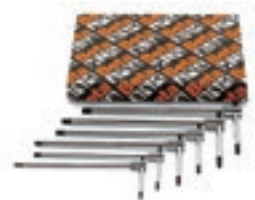

951AS/S6X
1/8-3/16-7/32-1/4-5/16-3/8

1 009510771

Beta

951TX

chiavi a T con tre estremità maschio per viti con impronta Torx®



Ø	L mm	L1 mm	Ø mm		
T6	125	63	4	3	009510806
T7	125	63	4	3	009510807
T8	125	63	4	3	009510808
T9	125	63	4	3	009510809
T10	150	63	4	3	009510810
T15	150	63	4	3	009510815
T20	175	76	5	3	009510820
T25	175	76	5	3	009510825
T27	195	87	6	3	009510827
T30	195	87	6	3	009510830
T40	215	99	7	3	009510840
T45	230	109	8	3	009510845
T50	250	122	9	3	009510850

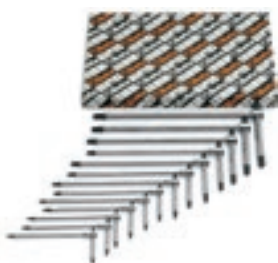

951TX/S6	1	009510866
T8-T10-T15-T20-T25-T30		
951TX/S13	1	009510863
T6-T7-T8-T9-T10-T15-T20-T25		
T27-T30-T40-T45-T50		

952

chiavi a T con bussola esagonale snodata

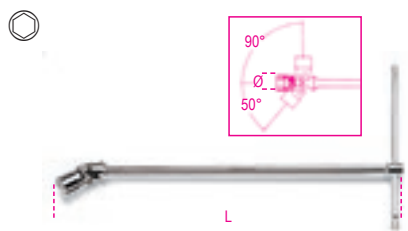

UNI 6743

Ø mm	Ø mm	L mm		
6	9,5	395	5	009520006
7	10,7	395	5	009520007
8	12,1	395	5	009520008
9	13,2	395	5	009520009
10	14,6	400	5	009520010
11	15,8	400	5	009520011
12	17,0	400	5	009520012
13	18,7	432	5	009520013
14	19,7	432	5	009520014
15	20,9	450	3	009520015
16	22,0	450	3	009520016
17	23,4	450	3	009520017
18	24,7	450	3	009520018
19	26,0	500	3	009520019
20	27,4	500	3	009520020
21	28,5	500	3	009520021
22	29,7	500	3	009520022
24	32,4	500	3	009520024



952/S7	1	009520074
8-10-11-13-14-17-19 mm		
952/S10	1	009520080
7-8-10-11-12-13-14-15-17-19 mm		
952/S18	1	009520083
6-7-8-9-10-11-12-13-14-15-16-17-18-19-20-21-22-24 mm		

952AS

chiavi a T con bussola esagonale snodata

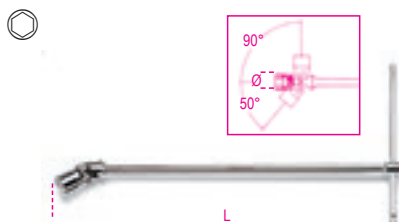

Ø	Ø mm	L mm		
1/4	9,5	395	2	009520256
5/16	12,1	395	2	009520258
3/8	14,6	400	2	009520260
7/16	15,8	400	2	009520261
1/2	18,7	432	2	009520263
9/16	19,7	432	2	009520264
5/8	22,0	450	2	009520266
11/16	23,4	450	2	009520267
3/4	26,0	500	2	009520269

952L

chiavi a T con bussola esagonale snodata, tipo lungo

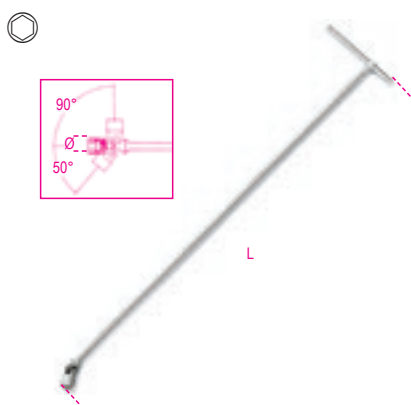

Ø mm	Ø mm	L mm		
10	14,6	930	1	009520410
12	17,0	1063	1	009520412
13	18,7	1100	1	009520413
14	19,7	1100	1	009520414
15	20,9	1100	1	009520415
16	22,0	1100	1	009520416
17	23,4	1100	1	009520417
18	24,7	1100	1	009520418
19	26,0	1100	1	009520419

952FTX

chiavi a T con bussola snodata per viti con testa a profilo Torx®

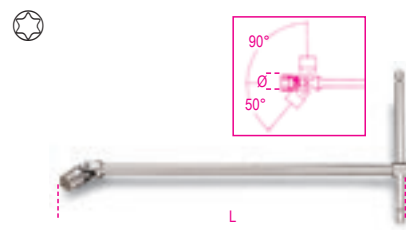

Ø mm	L mm		
E6	8	392	2 009520106
E7	9	392	2 009520107
E8	10	395	2 009520108
E10	13	400	2 009520110
E12	15	440	2 009520112
E14	17	490	2 009520114
E16	19	490	2 009520116
E18	21	490	2 009520118
E20	23	490	2 009520120



952FTX/S9	1	009520141
E6-E7-E8-E10-E12-E14-E16-E18-E20		

953

chiavi a T con maschio esagonale snodato

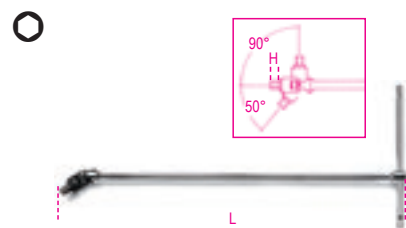

UNI 6754

mm	H mm	L mm		
3	5	395	5	009530130
3,5	6	395	3	009530135
4	6	395	5	009530140
4,5	7	395	3	009530145
5	7	395	5	009530150
6	9	400	5	009530160
7	10	425	3	009530170
8	11	425	5	009530180
10	13	440	5	009530200



953/S5	1	009530305
3-4-5-6-8 mm		
953/S9	1	009530301
3-3,5-4-4,5-5-6-7-8-10 mm		

953TX

chiavi a T con maschio snodato per viti con impronta Torx®

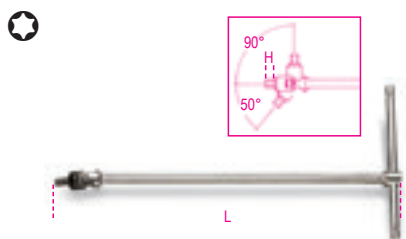

mm -"	H mm	L mm	
T20	11	396	2 009530020
T25	11	396	2 009530025
T27	11	396	2 009530027
T30	13	400	2 009530030
T40	13	400	2 009530040
T45	13	426	2 009530045
T50	14	442	2 009530050
T55	14	442	2 009530055



953TX/S8	
T20-T25-T27-T30	1 009530060
T40-T45-T50-T55	

955

chiave a tubo semplice per candele d'accensione

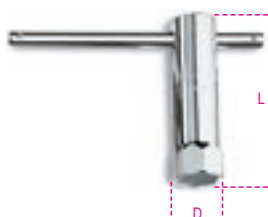

mm -"	D mm	L mm	
16	21	86	3 009550016
5/8			
20,8	29	86	3 009550021
13/16			

956C

chiavi a bussola con attacco quadro femmina 1/2" per candele d'accensione



mm -"	Ø mm	L mm	
14	18,8	70	3 009560008
9/16			
16	21,4	70	3 009560010
5/8			
17,8	23,6	70	3 009560011
11/16			
20,8	27,0	70	3 009560012
13/16			

956E

chiavi a bussola con attacco quadro femmina 3/8" per candele d'accensione



mm -"	Ø mm	L mm	
14	18,8	70	3 009560018
9/16			
16	21,4	70	3 009560020
5/8			
17,8	23,6	70	3 009560021
11/16			
20,8	27,0	70	3 009560022
13/16			

956F

chiavi a bussola con attacco quadro femmina 3/8" per candele d'accensione



mm -"	Ø mm	L mm	
14	18,8	70	1 009560114
9/16			
16	20,5	70	1 009560116
5/8			

956L

chiavi a bussola poligonale con attacco quadro femmina 1/2" tipo lungo, per candele d'accensione



mm -"	Ø mm	L mm	
14	20,2	250	2 009560214
9/16			
16	24,0	250	2 009560216
5/8			
17,8	24,0	250	2 009560217
11/16			
20,8	28,5	250	2 009560221
13/16			

957

chiavi a T con bussola snodata per candele d'accensione

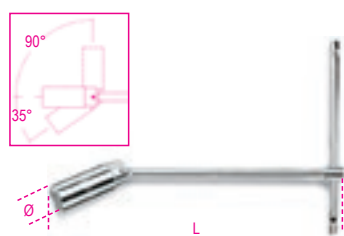

mm -"	Ø mm	L mm	
16	21,4	275	3 009570000
5/8			
20,8	27,0	275	3 009570001
13/16			

959

chiavi a T con bussola snodata tipo normale, per candele d'accensione

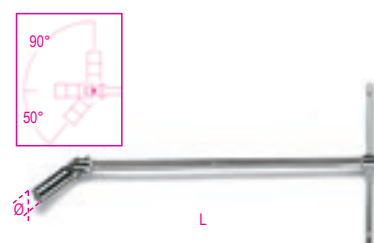

mm -"	Ø mm	L mm	
14	18,8	483	3 009590009
9/16			
16	21,4	483	3 009590010
5/8			
20,8	27,0	527	3 009590011
13/16			

959R

gommino e molla di ricambio per 956C - 956E - 957 - 959

959R/14	
956C/14-956E/14	3 009590223
959R/16	3 009590224
956C/16-956E/16	
957/16-959/16	
959R/17,8	3 009590225
956C/17,8-956E/17,8	
959R/20,8	3 009590226
956C/20,8-956E/20,8	
957/20,8-959/20,8-959L	

960

chiavi a bussola con attacco quadro femmina 1/2" per iniettori motori Diesel



mm	Ø mm	L mm	
27	36,5	77	2 009600027

960A

chiavi a bussola con attacco quadro femmina 1/2" per iniettori motori Diesel

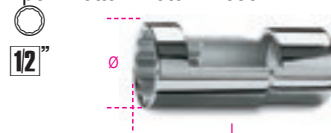

mm	Ø mm	L mm	
27	36,5	77	2 009600017



TECNOFIX S.r.l.

Via Brughetti, 4/G | 20813 Bovisio Masciago (MB) | Tel: 0362 690030 | info@tecnofixsrl.com

